

HLCM... Weighing module for 110 kg ... 4.4 t

SPECIAL FEATURES

- Equipped with load cell HLCB class D1 or C3, qualified for legal for trade applications according to OIML R60
- Optional legal for trade version as per NTEP (US/CA) III M5000 (up to and including 2.2 t)
- Compact installation at minimum installation height
- With stay rod
- Self-restoring due to pendle bearing
- Two versions available: Galvanized material and Stainless steel (preferred types)
- With anti-liftoff device and lifting device
- Optional explosion protection version as per ATEX, IECEx and FM (US/CA)
- Optional version with M12 male connector

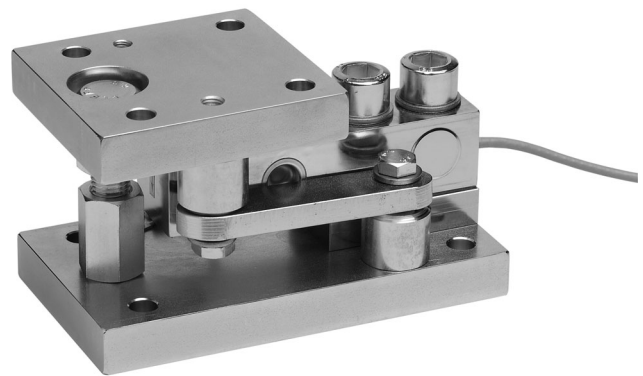

DIMENSIONS

Version with fixed cable

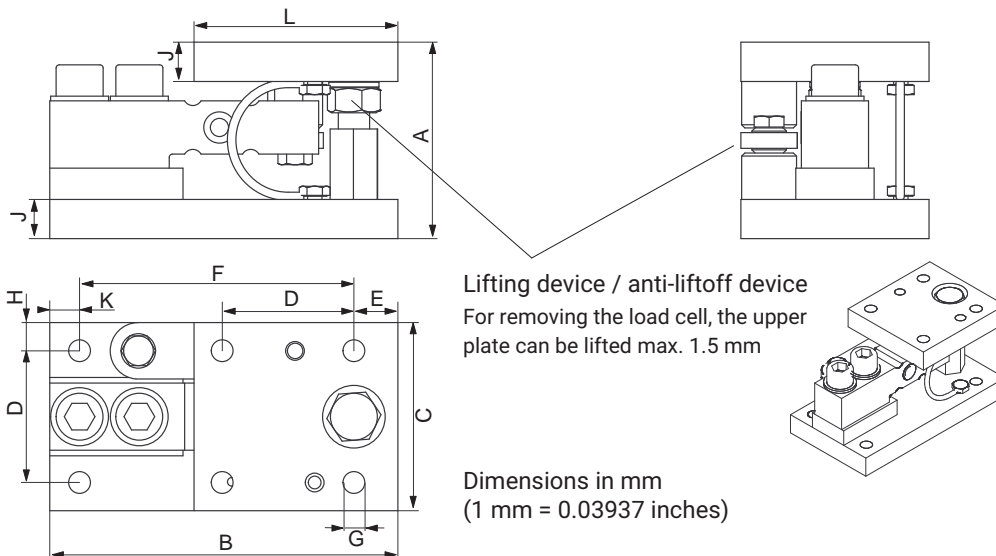

Max. capacity	A	B	C	D	E	F	ØG	H	J	K	L
110 kg; 220 kg; 550 kg; 1.1 t; 1.76 t	93.6 ^{±1.6}	170	100	70	17	136	13.5	15	19	17	104
2.2 t	125.3 ^{±2}	220	120	84	25.5	175	14	18	23	19.5	135
4.4 t	125.3 ^{±2}	220	120	84	25.5	175	14	18	23	19.5	135

Version with M12 male connector

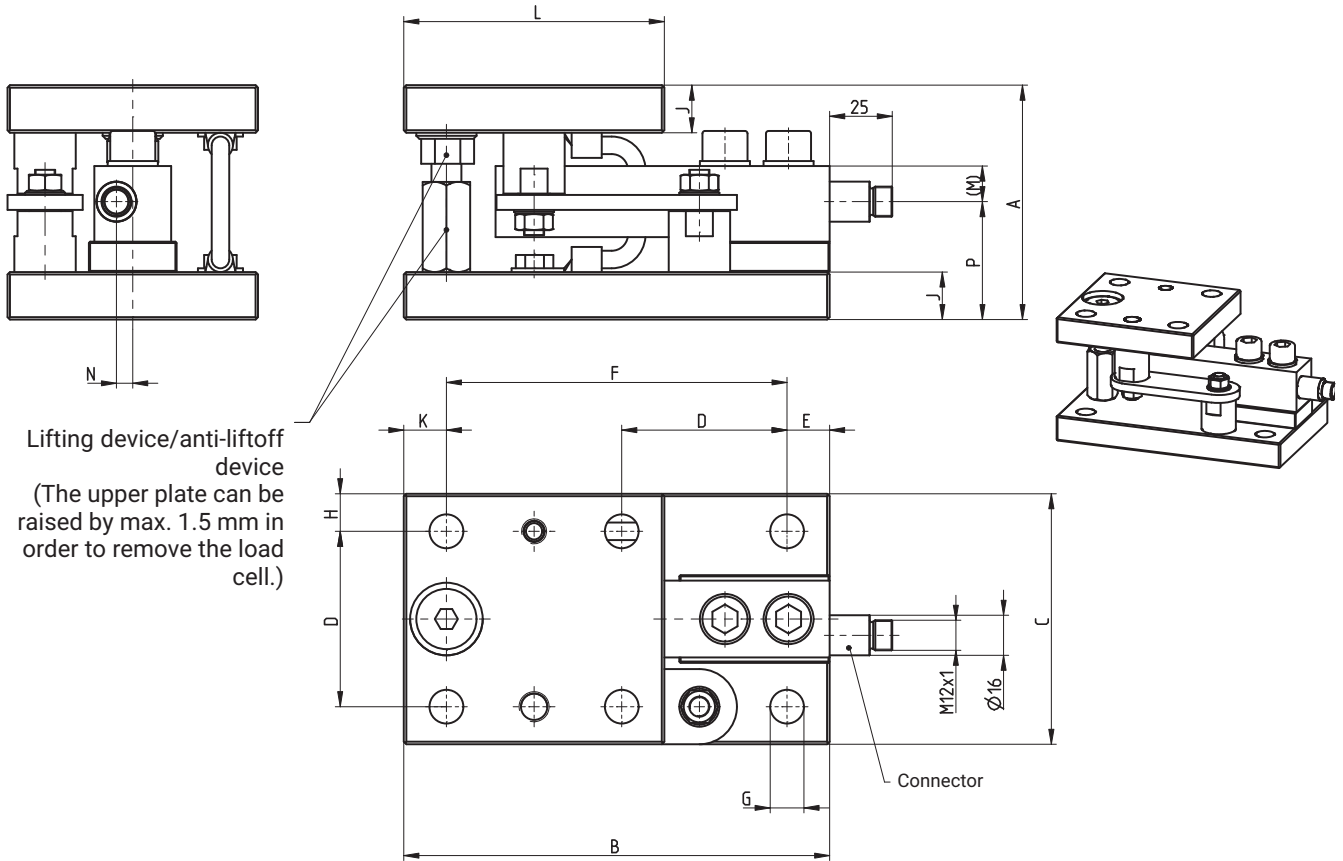

Dimensions in mm

Maximum capacity	A	B	C	D	E	F	ØG	H	J	K	L	(M)	N	P
220 kg; 550 kg; 1.1 t; 1.76 t	93.6±1.6	170	100	70	17	136	13.5	15	19	17	104	14.2	6.5	47.1
2.2 t	125.3±2	220	120	84	25.5	175	14	18	23	19.5	135	17	9.7	61.3
4.4 t												20.2	12.7	61.2

SPECIFICATIONS

Maximum capacity		110 kg; 220 kg; 550 kg; 1.1 t	1.76 t	2.2 t; 4.4 t
Limit load HLC/MLB... HLC/MLBR...	% of maximum capacity	150	150	120
Breaking load	% of maximum capacity	200		
Restoring force (for 1 mm side offset)	% of applied load	7.7		
Max. permissible horizontal shift transverse to the stay rod axis 1)	mm	1.5		
Max. permissible static horizontal force in stay rod axis	kN	10	22	
Max. permissible liftig force	kN	20	44	
Material		Galvanized or Stainless steel 2)		
Weight (depending on version, incl. load cell)	kg	7 ... 10		

1) For horizontal adjustment of upper module plate

2) According to EN 10088-1

For additional information on the appropriate load cells, please refer to the Data sheet HLC...

OPTIONS FOR HLCM

Explosion protection versions as per ATEX, IECEx and FM (US/CA)

- AI1/21 ATEX+IECEx+FM Zone 1/21, intrinsically safe;
 - ATEX/IECEx: II 2G Ex ia IIC T6/T4 Gb + II 2D Ex ia IIIC T125°C Db
 - FM(US/CA): Class I Zone 1 AEx/Ex ia IIC T4 Gb + Zone 21 AEx/Ex ia IIIC T125°C Db
 - FM(US): Class I, II, III Division 1, Groups A, B, C, D, E, F, G T4
- AI2/21 ATEX+IECEx Zone 2/21, not intrinsically safe;
 - ATEX/IECEx: II 3G Ex ec IIC T6/T4 Gc + II 2D Ex tb IIIC T125°C Db

MOUNTING EXAMPLE OF WEIGHING MODULES WITH STAY RODS

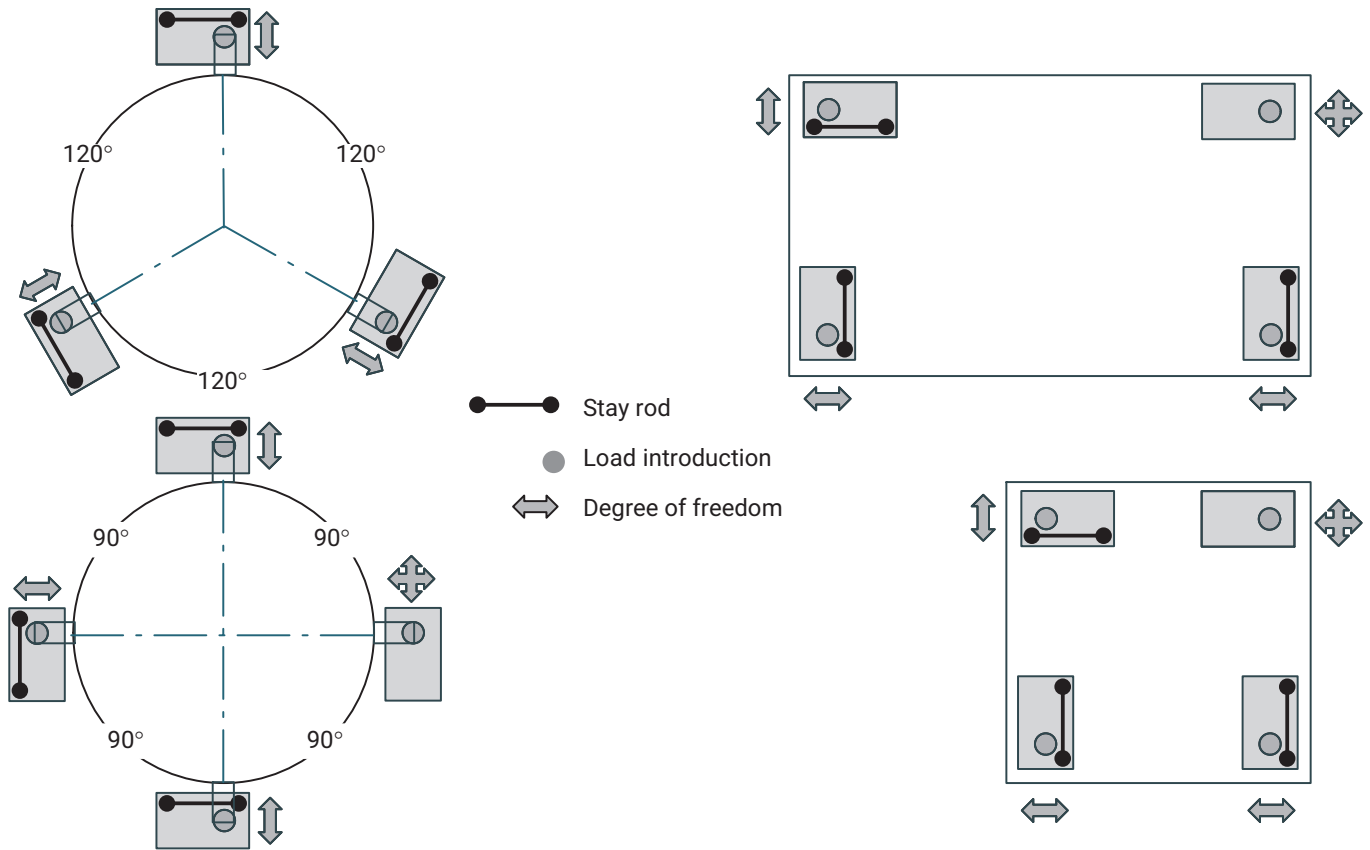

SCOPE OF SUPPLY

Weighing module complete mounted with pendle support, stay rod, grounding cable and load cell type HLCB

PLACING ORDERS

When placing an order please specify the ordering numbers from the tables. If you need other versions (accuracy classes, explosion protection, other cable lengths or materials, etc.) for the available products, please look in the overview "HLC/M-Modules (incl. load cell HLCB...), optional versions" on the next page. You can generate a specific ordering number there from your individual requirements.

Product numbers for HLC/M3LB modules (incl. HLCB... load cell), preferred types (without M12 male connector)

Type	HLC/M3LB
Material	Stainless steel ¹⁾
Accuracy class	C3 (OIML) ²⁾
Maximum capacity	Order no.
110 kg	1-HLC/M3LBR110KG
220 kg	1-HLC/M3LBR220KG
550 kg	1-HLC/M3LBR550KG
1.1 t	1-HLC/M3LBR1.1T
1.76 t	1-HLC/M3LBR1.76T
2.2 t	1-HLC/M3LBR2.2T
4.4 t	1-HLC/M3LBR4.4T

¹⁾ According to EN 10088-1

²⁾ In the maximum capacities from 110 kg up to and including 2.2 t, the load cells also have an NTEP IIIM 5000 label

HLC/M-MODULES (INCL. LOAD CELL HLCB...), OPTIONAL VERSIONS

Ordering number		
K-HLCM		
1	Code	Option 1: Material
	V	Galvanized
	R	Stainless
2	Code	Option 2: Accuracy class
	D1	D1 (OIML) [not with option 5 = N]
	C3	C3 (OIML) ¹⁾
3	Code	Option 3: Maximum capacity
	110	110 kg [not with option 5 = N]
	220	220 kg
	550	550 kg
	1100	1.1 t
	1760	1.76 t
	2200	2.2 t
4400	4.4 t	
4	Code	Option 4: Explosion protection
	N	No explosion protection
	AI1/21	ATEX+IECEX+FM Zone 1/21
	AI2/21	ATEX+IECEX Zone 2/21

5	Code	Option 5: Cable length
	N	Connector [only with option 4 = N and option 7 = B2]
	S3	3 m (standard) [only with option 3 = 110/220/550/1100/1760]
	S6	6 m (standard) [only with option 3 = 2200/4400]
	6	6 m [only with option 3 = 110/220/550/1100/1760]
	12	12 m
	20	20 m [only with option 7 = B2]
	3R	3 m (braided wire) [only with option 6 = B2 and option 3 = 110/220/550/1100/1760]
	6R	6 m (braided wire) [only with option 7 = B2]
	12R	12 m (braided wire) [only with option 7 = B2]
6	Code	Option 6: Other
	N	Without
7	Code	Option 7: Load cell type
	B1	HLCB1(IP68) ²⁾
	B2	HLCB2 (IP68/IP69K) ³⁾ [only with option 2 = C3]
8	Code	Option 8: Ground cable
	S	EEK standard (braided wire)
	H	Ground cable with smooth outer sheath [only with option 4 = N]

¹⁾ In the maximum capacities from 110 kg up to and including 2.2 t, the load cells also have a Class IIIM 5000 NTEP label. This does not apply to the version with male connector (option 5, code N).

²⁾ PVC outer sheath, gray

³⁾ TPE cable sheath, red or optionally with braided wire

Not all codes can be combined with each other. Please take heed of the terms in the square brackets!

CONNECTOR PIN ASSIGNMENT (W. OPTION 5, CODE N: CONNECTOR PIN ASSIGNMENT)

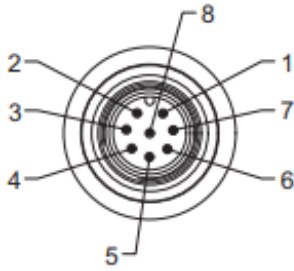

- Plug-in contact 1 = measurement signal (+)
- Plug-in contact 2 = not in use
- Plug-in contact 3 = sense lead (+)
- Plug-in contact 4 = not in use
- Plug-in contact 5 = sense lead (-)
- Plug-in contact 6 = excitation voltage (-)
- Plug-in contact 7 = excitation voltage (+)
- Plug-in contact 8 = measurement signal (-)

Pin assignment for 1-KAB168

Color code	Connection
White	Measurement signal (+)
Red	Measurement signal (-)
Blue	Excitation voltage (+)
Pink	Excitation voltage (-)
Green	Sense lead (+)
Gray	Sense lead (-)
Yellow	Not assigned
Brown	Not assigned

Pin assignment for 1-KAB175

Color code	Connection
White	Measurement signal (+)
Red	Measurement signal (-)
Blue	Excitation voltage (+)
Black	Excitation voltage (-)
Green	Sense lead (+)
Gray	Sense lead (-)

Connection cable for connection coupling

Connection cable with M12 F socket, 8-pin, TPU IP67, PUR cable sheath, 5 m long	1-KAB168-5
Connection cable with M12 F socket, 8-pin, TPU IP67, PUR cable sheath, 20 m long	1-KAB168-20
Connection cable with M12 F socket, 8-pin, stainless steel IP68/IP69, hygiene design, 3 m long	1-KAB175-3-1
Connection cable with M12 F socket, 8-pin, stainless steel IP68/IP69, hygiene design, 6 m long	1-KAB175-6-1
Connection cable with M12 F socket, 8-pin, stainless steel IP68/IP69, hygiene design, 12 m long	1-KAB175-12-1

CABLE ASSIGNMENT OF LOAD CELL CORRESPONDS TO STANDARD 6-WIRE CIRCUIT

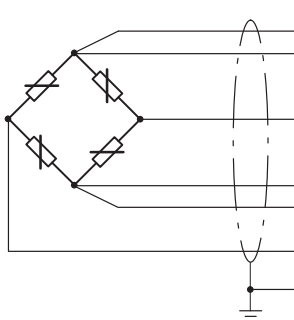

- (gray) Sensing element (-)
- (black) Bridge excitation voltage (-)
- (white) Signal (+)
- (blue) Bridge excitation voltage (+)
- (green) Sensing element (+)
- (red) Signal (-)
- (stranded connection wire) Cable shield connected to housing ground

Hottinger Brüel & Kjaer GmbH

Im Tiefen See 45 · 64293 Darmstadt · Germany
 Tel. +49 6151 803-0 · Fax +49 6151 803-9100
 www.hbkworld.com · info@hbkworl.com

Subject to modifications. All product descriptions are for general information only. They are not to be understood as a guarantee of quality or durability.