

## PRODUCT DATA

# LAN-XI Data Acquisition Hardware

## Frames, Modules and Front Panels

LAN-XI data acquisition hardware is a versatile system of modular hardware that consists of frames, modules\* and front panels.

Use a single module as a stand-alone data acquisition front end or collect multiple modules together in a frame to expand the channel count. Sample synchronization using precision time protocol (PTP) and GPS enable you to build distributed data acquisition systems comprised of multiple front ends.

LAN-XI hardware is the ideal data acquisition hardware for BK Connect®, PULSE™ LabShop, Sonoscout® and Test for I-deas.

LAN-XI also supports a programmer's interface: LAN-XI Open API (application protocol interface). All modules include access to the API as standard.

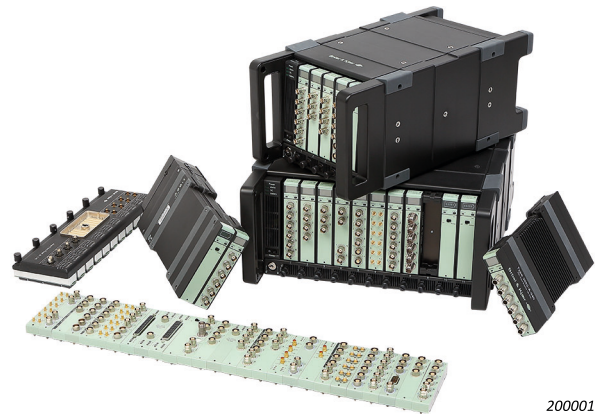

200001

## Uses and Features

### Uses

- Real-time, multichannel sound and vibration data acquisition
- Laboratory and field measurements
- System excitation for sound and vibration measurements
- Wireless front end for Sonoscout NVH Recorder, PULSE LabShop or BK Connect
- Stand-alone recorder
- In-vehicle NVH recordings

### Features

- 2 to 1000+ measurement channels
- Scalable configurations
  - Single-module systems
  - Multi-module systems collected in a frame
  - Distributed systems
  - Multiple separate distributed systems
- LAN interface
- GPS synchronization
- PTP synchronization
- Powered by mains, DC, battery or Ethernet
- Data transfer, power supply (PoE) and synchronization (PTP) via a single LAN cable
- Plug and play modules
- Liquid crystal display (LCD) on each module
- Web-based setup page for each module
- Frequency ranges of 25.6, 51.2, 102.4 or 204.8 kHz

- Absolute maximum input 60 V<sub>peak</sub> without damage
- Available channel types:
  - Multi-purpose input: direct voltage, CCLD, microphone preamplifier (0 or 200 V polarization voltage), charge
  - Low-frequency auxiliary
  - DC output
  - High-speed tacho input
  - CAN bus input
  - AES3 balanced input
  - Generator output
- Selectable floating or grounded input/output
- Conditioning of all sound and vibration transducers
- Dyn-X technology
- Interchangeable front panels
- Overload detection and indication, including out-of-band overload and generator overload
- Low out-of-band spurious noise
- Extremely low noise floor
- Indication of faulty conditioning on each channel connector
- Recording to SD memory card (WAV or BKC format)
- Rugged and light modules cast in magnesium
- Silent operation
- Full compatibility with PULSE LabShop and BK Connect
- Automatic detection of hardware and transducers
- Support of IEEE 1451.4-capable TEDS transducers
- Platform-independent API

\* For information about LAN-XI Light modules, visit [www.hbkworld.com](http://www.hbkworld.com).

## Applications

LAN-XI hardware can be used in a wide variety of applications.

- General sound and vibration measurement and analysis
- Noise source identification
- Sound power determination
- Pass-by noise
- Electroacoustics
- Acoustic material testing
- Structural dynamics
- Machine analysis and diagnostics
- Source path contribution
- Calibration systems
- Research and development

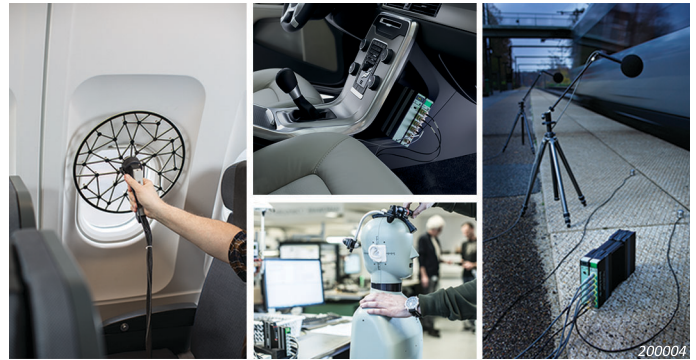

## System

LAN-XI data acquisition hardware covers a range of stand-alone input/output modules that can be used alone, in distributed networks or in frames holding up to 11 modules. LAN-XI hardware is extremely flexible and can be easily reconfigured, as requirements demand. For example, a module can be used in the field with a DC power supply then as part of a distributed measurement system with power over Ethernet (PoE). Additionally, the module can be easily reconfigured with different connectors using interchangeable front panels.

LAN-XI hardware enables you to build distributed systems where the data acquisition front ends are close to the measurement object. Furthermore, distributed systems of single modules minimize the requirements for transducer cables – all you need between the modules and the PC are LAN cables and an Ethernet switch. A single LAN cable transfers data, provides power (PoE) and synchronizes samples (PTP).

Table 1 Configuration examples

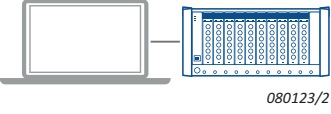
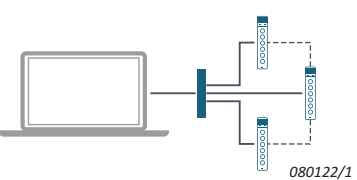
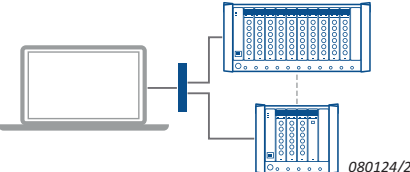
<p><b>Single Front-end System</b></p> 	<p><b>Single Module</b></p> <ul style="list-style-type: none"> <li>• Any single data acquisition module</li> <li>• LAN cable: PoE, data transfer</li> <li>• Options: Battery module, interchangeable front panel</li> </ul>
	<p><b>Multiple Modules in a Frame</b></p> <ul style="list-style-type: none"> <li>• Single 5- or 11-module frame</li> <li>• Up to 5 or 11 modules</li> <li>• LAN cable: data transfer</li> <li>• Power via mains or battery</li> <li>• Options: Battery module(s), interchangeable front panels</li> </ul>
<p><b>Distributed System</b></p> 	<p><b>Single-module Front Ends</b></p> <p>Network switch and LAN cable for PoE, PTP sync between modules</p> <ul style="list-style-type: none"> <li>• Any number of input/output modules</li> <li>• Network switch</li> <li>• LAN cable: PoE, PTP sync, data transfer</li> <li>• Options: Battery modules, interchangeable front panels</li> </ul>
	<p><b>Mixed Front Ends</b></p> <p>Network switch, PTP sync between frames</p> <ul style="list-style-type: none"> <li>• Multiple 5- or 11-module frames</li> <li>• Up to 5 or 11 modules in each frame</li> <li>• Network switch</li> <li>• LAN cable: data transfer, PTP sync</li> <li>• Power via mains or battery</li> <li>• Options: Battery modules, interchangeable front panels</li> </ul>

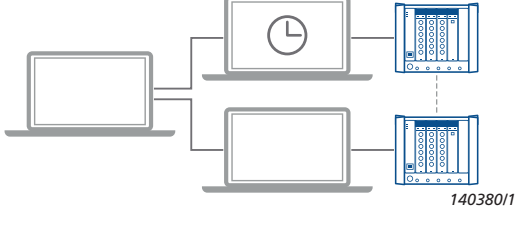
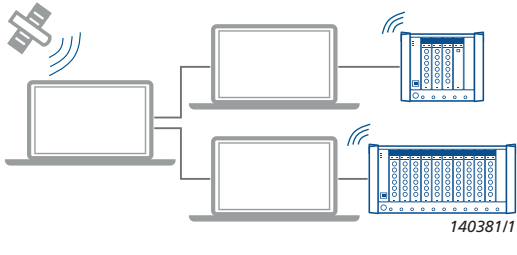
<p><b>Multiple Separate Systems</b></p> 	<p><b>PTP Sync</b> PTP master frame uses time from PC to sync frames, data collected on one PC for post-processing</p> <ul style="list-style-type: none"> <li>• Multiple 5- or 11-module frames</li> <li>• Up to 5 or 11 modules in each frame</li> <li>• LAN cable: data transfer, PTP sync</li> <li>• Power via mains or battery</li> <li>• Options: Battery modules, interchangeable front panels</li> </ul>
	<p><b>GPS Sync</b> GPS sync between frames, data collected on one PC for post-processing</p> <ul style="list-style-type: none"> <li>• Multiple 5- or 11-module frames</li> <li>• Up to 5 or 11 modules in each frame</li> <li>• LAN cable: data transfer</li> <li>• Power via mains or battery</li> <li>• Options: Battery modules, interchangeable front panels</li> </ul>

### Managing the Setup

Configurations of one or more LAN-XI modules and frames are easily managed using the Front-end Setup program of BK Connect and PULSE LabShop. You can select modules and frames, access the modules' web-based interface, change IP addresses, flash the modules' LEDs and update firmware.

### Synchronizing the Samples

For most sound and vibration applications, sample-synchronous and phase-matched measurements are a must. If no synchronization method is used, two or more sampling systems will drift apart over time. Even the best clock systems available will, in less than 10 seconds, drift so far apart that the sample correlation will drop to an unacceptable level for high-quality sound and vibration measurements.

#### PTP

Precision time protocol (PTP) makes it possible to synchronize the clocks in the system components with sub-microsecond accuracy using the same LAN connection used for transferring the measurement data.

PTP synchronization measures the delays between individual PTP components using a special algorithm (see the IEEE 1588 standard\*). By doing this, all delays can be accurately measured,

and the individual clocks can be set to exactly the same time. On top of this, the phase drift of the 'slave' clocks is continuously measured and counter-adjusted by a control loop, which adjusts the slave clocks' speed.

All Brüel & Kjær sound and vibration applications will work with most† high-performance 1-gigabit network switches, but have superior phase characteristics using a dedicated network switch with PTP support, such as UL-0295.

#### GPS

GPS synchronization can be used in a standard LAN-XI data acquisition system with PTP among modules and frames, but with GPS in the PTP master, the clock is now absolute and very accurate. You can also have several, completely detached, LAN-XI systems that each record their data with an absolute GPS time stamp and with data samples locked to the GPS clock.

GPS sample synchronization is available with LAN-XI Frame Types 3660-C-100 and 3660-D-100.

\* IEC 61588/IEEE 1588-2008, Precision Clock Synchronization Protocol for Networked Measurement and Control Systems

† The switch must treat IEEE 1588 packages with same priority as data traffic, some 'non-PTP-aware' switches do not.

**Fig. 1** PTP enables distributed systems where modules are situated close to the measurement object. Using a LAN cable for data transfer, PoE and PTP drastically reduces cabling

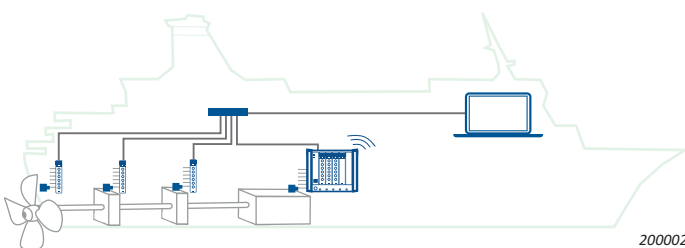

**Fig. 2** Synchronize data over large distances with GPS

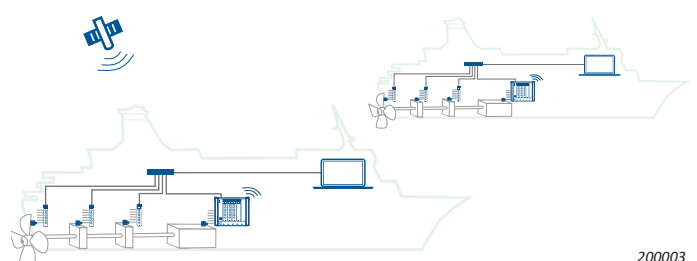

LAN-XI frames enable you to collect modules together to increase the channel count of your front end, as well as provide additional functionality. Frames (with one or more modules) can be used for single front-end systems or as part of a distributed system.

**Frames with GPS**

Types 3660-C-100 and 3660-D-100\* house up to 5 and 11 modules, respectively, in a robust casing for industrial and hard everyday use. Each frame operates silently and has a 1-gigabit LAN backbone, which provides full throughput of all channels.

Modules lock or screw into place in the frame. It is easy to swap or remove modules to, for example, reconfigure your front end, use only a single module or send a module for calibration or repair.



**Cooling**

Operation is silent unless the cooling fans activate. Cooling fans activate when the front end exceeds the maximum safe operating temperature.

**GPS Synchronization**

GPS defines the absolute time and provides an accurate time base for synchronized data acquisition within a system or between systems in different locations. The GPS time stamp ensures that the measurements are sample synchronized, enabling cross-spectral analysis between channels.

**Power Supply**

Types 3660-C-100 and 3660-D-100 both have an integral transformer for connecting a 90 – 264 V AC, 47 – 63 Hz mains power supply or an 11 – 32 V DC supply. In addition, each frame can house up to two battery modules, which are capable of powering nine input/output modules for up to 40 minutes. Batteries can be hot-swapped to extend operation time. Frames cannot be powered by PoE.

**DC Output and Additional Ethernet Port**

Types 3660-C-100 and 3660-D-100 have a 12 V DC, 1 A output (EIAJ-05 connector) with current protection to provide PoE for accessories such as a switch, a wireless access point (WAP) or a camera. Cables for these accessories must be purchased separately.

\* Types 3660-C-100 and 3660-D-100 replace LAN-XI Front-end Frame Types 3660-C and 3660-D.

**Wireless LAN Frame**

Wireless LAN Frame  
Type 3660-A-20x combines Battery Module Type 2831-A and any single data acquisition module to create a truly wireless data acquisition front end. The frame is perfect for in-vehicle NVH recordings, for making remote controlled recordings as a stand-alone recorder, or for use as the access point in wireless networking.



200005

A spring-loaded screw under the frame's easy-to-remove cover secures the frame to the battery/data acquisition module combination, and built-in storage for the hex key ensures you always have the right tool. Once connected, the module's web-based interface shows status information for the frame.

**Versions**

The frame is available in two versions: Type 3660-A-200 and Type 3660-A-201. Both versions feature the same functionality, the difference being that Type 3660-A-201 is for use in Japan (see product data [BP 2487](#)).

**Power Supply**

The battery module provides power for the front end. If powered from DC input, the battery acts as an uninterruptible power supply (UPS) for several hours.

**Configurations**

There are two common configurations for LAN-XI front ends based on Type 3660-A-20x†:

- Connected to a PC running BK Connect or PULSE LabShop applications, visit [www.hbkworld.com](http://www.hbkworld.com) for more information
- Connected to an Apple® iPad® running the Sonoscout App

† The attached data acquisition module connects to only one wireless LAN at a time, and the wireless device (PC or tablet) can connect to only one Type 3660-A-20x at a time.

The modules are plug-and-play devices cast in magnesium for a rugged yet light industrial design perfect for use in the field. They do not have a fan, so they operate silently and can run on AC, DC, battery or power over Ethernet (PoE). A mains power adaptor is included with each module.

The various data acquisition modules have different input and output channel configurations and input ranges. Each data acquisition module comes with a standard front panel, but most modules are also fully compatible with at least one other optional front panel. Modules can be mounted in a frame, or two or more modules can be attached to each other using integrated screws\*.

Visit [www.hbkworld.com](http://www.hbkworld.com) to find additional information, including product data for LAN-XI Module Types 3057 and 3058 and LAN-XI Light Module Types 3676 and 3677.

4- or 6-channel Input Module  
Type 3050, 51.2 kHz  
Type 3050 is designed to cover as many sound and vibration measurement applications as possible. It comes in two basic variants, offering the choice between four and six high-precision input channels with an input range from DC to 51.2 kHz.



120510

3-channel Input Module  
Type 3052, 102.4 kHz  
Type 3052 is specifically designed to measure high-frequency (> 50 kHz) sound and vibration signals. It has three input channels with a frequency range from DC to 102.4 kHz. Combined with a dynamic range of 160 dB, this ensures that demanding measurement needs can be met.



120511

12-channel Input Module  
Type 3053, 25.6 kHz  
A 12-channel input module that delivers a compact and cost-efficient solution for high-channel-count applications. Standing alone, Type 3053 is the world's smallest 12-channel sound and vibration data acquisition front end.



120512

High-speed Tacho Module  
Type 3056, 51.2 kHz  
Type 3056 is designed for applications that require monitoring low-frequency voltage signals along with the sound and vibration signals. The module offers a combination of four input channels and eight auxiliary channels.



120513

The four BNC connectors have an input range from DC to 51.2 kHz and support high-speed (HS) tacho signals. This lets you record the signals needed to perform angle domain (crank angle) analysis using BK Connect Angle Domain Analysis Type 8440.

The two circular 10-pin connectors provide eight simultaneously sampled, low-frequency auxiliary channels and four DC outputs. The DC outputs can be controlled as functions of tolerance-curve and level-meter results. This is used for simple on/off control of third-party equipment in production test pass/fail, etc.

Bridge Module Type 3057,  
102.4 kHz  
Type 3057-B-030 is a three-channel module with an input range of DC to 102.4 kHz. It is intended primarily for dynamic measurements using BK Connect with piezoresistive and variable-capacitance accelerometers and/or pressure sensors. The module also supports strain gauges – full, half and quarter-bridge – as well as strain-gauge-based transducers such as force, pressure and torque sensors. Direct input and CCLD transducers are also supported, including microphones and accelerometers for general sound and vibration measurements.



150411

Type 3057 contains a built-in bridge excitation supply that can be configured either as a 0–10 V constant voltage source with optional remote sensing, or as a 0 – 25 mA constant current source.

CAN Bus Module  
Type 3058, 25.6 kHz  
Type 3058 is a low-noise data acquisition unit with eight analogue dynamic input channels and two independent CAN bus channels. Four of the eight analogue channels can be configured as two balanced input channels for digital input according to AES3 for connecting Sound Quality HATS (head and torso simulator). In addition, Type 3058 supports both high- and low-speed CAN, OBD-II and J-1939, making it well-suited to automotive applications.



170085

The analogue input channels have an input range from DC to 25 kHz, support direct voltage signals, and provide conditioning for CCLD transducers such as microphones, accelerometers, binaural recording headsets and HATS.

\* Connecting two or more modules will reduce maximum ambient operating temperature. There is no reduction in ambient temperature limit when using a single module with a Type 2831-A battery.

**Input/Output Module  
Type 3160, 51.2 kHz**

Type 3160 features a combination of input and generator output channels, making it one of the most versatile data acquisition modules available. The module is ideal for applications where system excitation is required such as audio and electroacoustic test applications.



Type 3160 comes in two basic variants, offering the choice between 2 input/2 output or 4 input/2 output channels. All input and output channels have a frequency range of DC to 51.2 kHz.

**High-frequency Input/Output  
Module Type 3161, 204.8 kHz**

Type 3161 is for high-frequency applications such as transducer calibration and underwater defence applications. It offers a combination of one input channel and one generator output channel. Both input and output channels have a frequency range of DC to 204.8 kHz. The combination of input connectors – Direct/CCLD, 200 V and Charge – on the front panel allows connection to virtually any microphone and accelerometer, including direct connection to Hydrophone Types 8103, 8104, 8105 and 8106.



**Battery Module Type 2831-A**  
Type 2831-A is a rechargeable Li-ion battery with an output voltage of 14.8 V and a capacity of 6400 mAh. It can be connected to a single module or mounted in a frame.



One battery can power a single module for over seven hours or provide over 40 minutes of operation in a multi-module frame. Two batteries can be used simultaneously for over 80 minutes of continuous power for a full frame.

On the front panel, five LED status indicators show the remaining capacity. When a battery is used in a LAN-XI frame, charging status and remaining capacity can be checked via software.

**Charging**

The battery module can be charged in a LAN-XI frame via AC (mains) or DC (>12.5 V, 12 V car with the engine running), or with a dedicated external charger. Type 2831-A includes an external mains charger (ZG-0880). An optional external DC charger is also available (ZG-0858).

**Uninterruptible Power Supply**

Type 2831-A can be used as a UPS, providing power to the module or frame if external power is temporarily lost (for example, in a car when the ignition switch is turned off).

**Note:** To act as a UPS for a single module, the battery module must be connected to the input/output module using ZH-0686, a single-module-to-battery power adaptor included with the battery module.

**Overview of LAN-XI Data Acquisition Modules**

TYPE NUMBER	INCLUDED FRONT PANEL	CHANNELS	CONNECTORS	FREQUENCY RANGE	SUPPORTED SIGNAL TYPES*
3050-A-040-R	UA-2100-040	4 general-purpose input	4 × BNC	0 to 51.2 kHz	Direct voltage, CCLD <sup>†</sup> , microphone preamplifier (0 or 200 V polarization voltage), charge <sup>‡</sup>
3050-A-060-R	UA-2100-060	6 general-purpose input	6 × BNC	0 to 51.2 kHz	
3052-A-030-R	UA-2100-030	3 high-frequency input	3 × BNC	0 to 102.4 kHz	
3053-B-120-R	UA-2107-120	12 general-purpose input	SMB	0 to 25.6 kHz	Direct voltage, CCLD, charge <sup>‡</sup>
3056-A-040	UA-2111-040	4 general-purpose/HS tachometer input	4 × BNC	0 to 51.2 kHz	Direct voltage, CCLD, mic. preamp. (0 or 200 V polarization voltage), charge <sup>‡</sup> , HS tachometer, auxiliary
		8 auxiliary input	2 × 10-pin circular		
		4 DC output			
3057-B-030-R	UA-2121-030	3 bridge sensor measurements/general-purpose input	3 × 15-pin D-sub	0 to 102.4 kHz	Bridge, direct voltage, CCLD
3058-B-080	UA-3101-080	8 general-purpose input, 4 of which create 2 × AES3 balanced input	8 × SMB	0 to 25.6 kHz	Direct voltage, CCLD, tachometer, balanced, CAN bus
		CAN bus	2 × 8-pin circular		
3160-A-022-R	UA-2100-022	2 general-purpose input	2 × BNC	0 to 51.2 kHz	Direct voltage, CCLD, microphone preamplifier (0 or 200 V polarization voltage), charge <sup>‡</sup>
		2 generator output	2 × BNC		
3160-A-042-R	UA-3100-042	4 general-purpose input	4 × BNC	0 to 51.2 kHz	
		2 generator output	2 × BNC		
3161-A-011-R	UA-2117-011	1 high-frequency input	1 × BNC 1 × 7-pin circular 1 × TNC	0 to 204.8 kHz	Direct voltage, CCLD, microphone preamplifier (0 or 200 V polarization voltage), charge
		1 generator or monitor output	2 × BNC		

\* Supply for older MM-0012 and MM-0024 photoelectric tachometers not available. Compatible with CCLD Laser Tacho Probe Type 2981. RS-232 connector for remote control not available

† Constant current line drive, also known as DeltaTron<sup>®</sup> (ICP and IEPE compatible)

‡ Requires a charge-to-CCLD converter, such as Type 2647

Assistance and Feedback

Hardware Interface

Each module has a display that you can toggle between module ID, IP address, PTP status and any error indications, including self-test and overload. The display automatically changes if an error arises.

Each channel has a light emitting diode (LED) colour-coded to indicate its condition:

- Green – active input channel
- Red – input overload; cable, transducer or conditioning fault
- Purple – input overload during recording session with LAN-XI Notar stand-alone recorder
- Yellow – transferring TEDS data
- Blue – generator output
- Blue/Red (alternating) – error on generator output, overload or cable short-circuit



When used with TEDS transducers, the clear indication of the selected channel greatly simplifies system setup.

Together, the display and LED can help you to locate a specific module or channel to determine whether the system is functional and configured correctly and whether the transducers are in good working order.

Web-based Interface

Each module has a web-based interface that you can access using a web browser. Use the interface to find information about the module, open the recorder application (LAN-XI Notar), make changes to its configuration, update its firmware and more.

Analysis Software Interface

BK Connect, PULSE LabShop, Sonoscout, and Test for I-deas provide an interface to your LAN-XI front end. The interface enables you to set up and monitor your front end through the analysis software.

BK Connect Hardware Setup allows you to connect to your front end and set up your channels while real-time monitors allow you to check that everything is set up properly before data acquisition.

In PULSE LabShop, the level meters allow you to easily monitor whether your system is working as intended and, if not, where any attention is needed for correcting transducer mounting or cabling.

Fig. 3 BK Connect Hardware Setup: Hardware Matrix (graphical representation of a LAN-XI front end) and Monitor

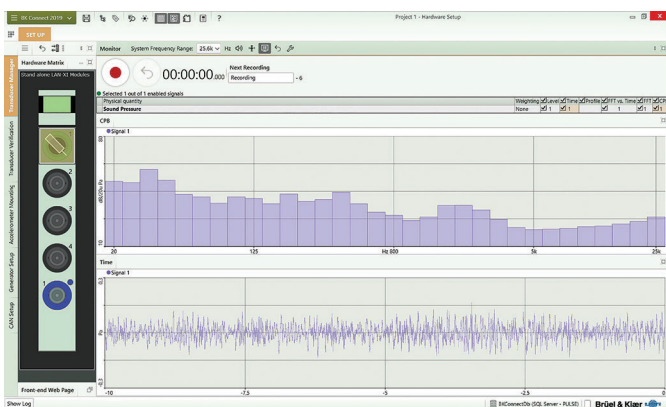

Front-end Setup

The Front-end Setup program provides an essential interface for configuring your front end. It also provides access to diagnostic and verification tools which give you a comprehensive overview of the digital and analogue components of your front end.

- Diagnostic tool: Provides a network test for diagnosing network issues and an analog and digital self-test for testing sensitivity, linearity, input noise, distortion and cross-talk using a LAN-XI module with an internal generator. Results can be exported in XLS format for archiving or sending to HBK
- Verification tool: Checks that the electrical noise, distortion and input range levels and the high-pass filter setting of the modules are still within their specifications, which eliminates a source of uncertainty in your measurement chain

IP Addresses

The module can be configured to use dynamic or static IP addressing. To do so, use the control button and display on the module or access the web-based interface:

- If the modules are set up to use dynamic IP addresses (default), the modules automatically receive their IP addresses from a DHCP server on the network. If this is not found, as in the case where a module is connected directly to a PC, the module will use 'link-local' ('auto-IP'). This means that an address in the 169.254.xxx.xxx range is selected. A PC with Windows® 7, 8.1 or 10 operating system will by default do the same, which means that the two can communicate
- If static addresses are selected, they can be changed later by using the Front-end Setup program of BK Connect and PULSE LabShop

Power over Ethernet (PoE)

PoE is implemented according to IEEE 802.3af. With a suitable network switch, the power needed for single modules is carried by screened shielded twisted pair (S/STP or S/FTP) CAT6 LAN cables rather than by separate power cables. This minimizes the number of cables required and results in lower cost, less downtime, easier maintenance and greater installation flexibility. Switches with PoE and PTPv2 support, such as UL-0295 (8 ports), and PoE injectors, such as ZyXEL® PoE12-HD (single port), can be used.

Stand-alone Recorder

With firmware version 2.9.0.552 or later, most data acquisition modules can record time data to a secure digital (SD) memory card (up to 16 GB\*) in BKC and WAV format. This means that LAN-XI modules are small, rugged and portable data recorders, eliminating the need for a computer to record data.

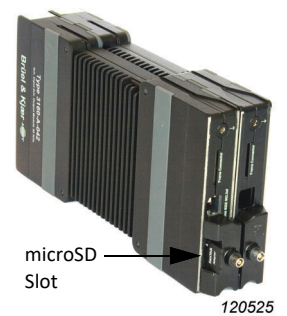

This functionality is available on all LAN-XI modules except Type 3057-B-030. Furthermore, auxiliary signals and high-speed tacho signals from Type 3056 are not supported.

\* Tested and guaranteed with SD card UL-1018

### Setup, Control and Display

Use the module's web-based interface to set up (bandwidth, number of channels, signal conditioning, etc.), control the recording and view feedback. This means that a mobile device with a web browser can be used to control the recorder remotely. Alternatively, you can use the module's display screen to control recording and view feedback, for example available memory and overload.

With Battery Module Type 2831-A, the system has an extremely long measurement time of over seven hours. For longer recording sessions, the battery can be replaced in the field and chargers are available for both mains and external DC (for example, in-vehicle) charging.

### Data Handling

Small and rugged solid-state memory cards have no shock-sensitive moving parts like hard drives. A 16 GB SD card allows nearly 4 hours of recording with 6 channels at 25.6 kHz bandwidth (65.5 kHz sampling frequency). The memory card is removable so stored data can be transferred by placing the memory card in a PC card reader. You can also download data over a network connection.

## LAN-XI Front Panels

Most modules are fully compatible with at least one other optional front panel. The standard front panel supplied with the data acquisition module can be removed then replaced with an optional front panel. This results in fewer patch panels, less cable 'spaghetti', fewer cable adaptors and faster system setup. Visit [www.hbkworld.com](http://www.hbkworld.com) to find more information about the individual front panels, including a product data.

### Built-in Protection

To protect against front panel/module combinations that are not allowed, there are a few built-in protections. The module will stop during power-up and display an error message if a faulty combination is used, and it is physically impossible to attach some front panels to some modules.

## About the Channels

### Input Channels

The front panels feature multi-purpose input channels that can be used to connect and condition all relevant sound and vibration transducers including:

- Microphone preamplifier with prepolarized microphone
- Microphone preamplifier with 200 V microphone polarization voltage (A-variants only)
- CCLD microphones
- Proximity probes
- Charge accelerometers
- CCLD accelerometers
- DC accelerometers (differential bridge input)
- Charge transducers (via CCLD converter)
- High-speed tachometer
- AC/DC

All input channels have automatic DC offset compensation, an extremely low noise floor and low out-of-band spurious noise.

LAN-XI Open Application Protocol Interface (API)  
LAN-XI Open API is a lightweight, platform-independent programmer's interface for customized control of LAN-XI hardware and access to real-time data. The API is available for modules running firmware 2.10.0.344 or later.

Users can use LAN-XI Open API to write custom software:

- Set up one or more modules as single data-acquisition front end(s) using a variety of synchronisation methods such as PTP. This could potentially be a completely detached program in C# for basic setup
- Configure module(s), including use of channels, bandwidth, filter settings, CCLD and polarization voltage
- Stream 24-bit samples in real time, or record to an SD card in BKC or WAV format
- Manage generator output, CAN functionality and bridge measurements
- Perform TEDS detection and read back the results
- Write raw data from your LAN-XI front end to MATLAB®, for example

Visit [www.hbkworld.com](http://www.hbkworld.com) to find more information about the open API.



080195

### Independent Channels

The input channels on a module can be set up independently. You can set up the high-pass filters and input gain separately and attach different types of transducers to different channels. The microphone polarization voltage can be switched on or off for each channel in the analysis software.

### IEEE 1451.4 Transducers

All input modules support TEDS transducers. This allows automatic front-end and analysis software setup based on TEDS information stored in the transducer, for example, sensitivity, serial number, manufacturer and calibration date. In PULSE LabShop, the individual frequency response of a transducer can be corrected for using PULSE's transducer response equalization, REq-X, to achieve higher accuracy over extended frequency ranges.

### Dyn-X – Single Range from 0 to 160 dB

Dyn-X is a technology that uses stacked analogue-to-digital converters (ADCs) to give the modules a single input range from 0 to  $10 V_p$  and a useful analysis range exceeding 160 dB. Dyn-X is on all input channels, except for Type 3053.

Fig. 4 Simplified block diagram of Dyn-X principle

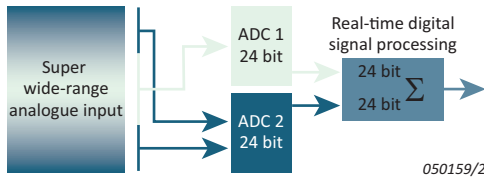
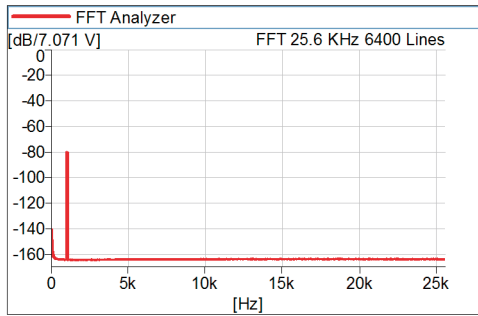

Fig. 5 160 dB analysis in one range. An FFT measuring a 1 kHz signal 80 dB below full scale ( $7 V_{rms}$ ). Note that noise and all spurious components measure 160 dB below full-scale input



With Dyn-X, the entire measurement and analysis chain matches or outperforms the transducer used for measurement. It eliminates the need for an input attenuator for ranging the analysis-system input to the transducer output. All you need to do to get excellent results is choose the right transducer. Covering everything in one input range, there is no worry about overloads, under-ranged measurements or discussions about the validation and verification of measurement results. With no need for trial runs in order to ensure that the input range is correct, you have a far greater certainty of getting measurements right first time.

Table 2 Examples of measurement situations and applications where Dyn-X technology can be usefully employed

When time is limited	<ul style="list-style-type: none"> <li>• Test cells</li> <li>• Wind tunnels</li> <li>• Road testing</li> <li>• Flight testing</li> </ul>
Where there is minimal user interaction	<ul style="list-style-type: none"> <li>• Road testing</li> <li>• Field testing</li> </ul>
When testing is unattended	<ul style="list-style-type: none"> <li>• Production line</li> <li>• Noise monitoring</li> </ul>
When signal levels are unknown	<ul style="list-style-type: none"> <li>• Run up/down</li> <li>• Field testing</li> </ul>
High-dynamic applications	<ul style="list-style-type: none"> <li>• Impulsive testing, room acoustics</li> <li>• Run up/down</li> <li>• Electroacoustics</li> <li>• Structural measurements</li> </ul>
When an overview of the whole measurement scenario is difficult	<ul style="list-style-type: none"> <li>• When measuring many channels</li> <li>• When combining signal types: vibration, sound, temperature, pressure, rpm, etc.</li> <li>• Test cells</li> <li>• In-car testing</li> <li>• Sound, vibration and other parameters involved</li> </ul>
When you need to get the measurement right the first time	<ul style="list-style-type: none"> <li>• Crash testing</li> <li>• Destructive testing</li> <li>• Heavy machinery – run up/coast down</li> </ul>

### Overload

Input channels have an input voltage up to  $10 V_{peak}$  and extended range up to  $31.6 V_{peak}$ , with an absolute maximum input of  $60 V_{peak}$  without damage.

Overload indications for input channels include (see Specifications for details):

- Signal overload with adjustable detection level
- CCLD overload: detection of cable break, short-circuit or CCLD transducer working point fault
- Microphone preamplifier overload: detection of microphone preamplifier current consumption too high or too low
- Common mode voltage overload: relevant when input coupling is floating

### Overload Protection

If the signal input level significantly exceeds the measuring range, the input will go into protection mode for at least 0.5 s until the signal falls again. While protected, the input is partly switched off and the input impedance is greatly increased. (The measured value will be strongly attenuated but still detectable.)

### Detecting Conditioning Errors

The modules use two methods to detect transducer cable breaks and incorrect conditioning. For microphones, their supply current is monitored; for CCLD accelerometers (or microphones using CCLD preamplifiers), the supply voltage is monitored. If conditioning errors, such as a broken cable, are detected, an error is indicated as an overload on the specific channel.

### Ground-loop Noise Suppression

You can set the input to floating or grounded in the analysis software. The floating/grounded, differential input design and the fact that all external connections (LAN, power supply) are galvanically isolated in the module provide optimal ground-loop noise suppression.

### Output Channels (Types 3160 and 3161 only)

The output channels can be used as high-quality signal generators with a frequency range from 0 to 51.2 kHz (Type 3160) or 204.8 kHz (Type 3161) and can supply the signals necessary for performing system analysis. Type 3160 can be used to generate dual swept sine, pink-noise, white-noise, or pseudo-random signals; Type 3161 cannot.

Generator channel(s) are indicated by blue LED on the front panel.

The modules are designed around a powerful digital signal processor and a low-noise, 24-bit, digital-to-analog converter and have exceptional flexibility, stability and accuracy. Output levels are adjustable from  $10 \mu\text{V}_{\text{peak}}$  to  $10 \text{V}_{\text{peak}}$ . The output signal is provided by a BNC connector and can be referred to ground or floating. It is possible to add a DC offset, but any unwanted DC offset is automatically removed.

The output channels have an extremely low noise floor, high amplitude and frequency linearity, and low out-of-band spurious noise. They are capable of heavy complex loading without instability and provide full output phase control among LAN-XI modules.

### Waveforms

Waveforms are determined by software. PULSE LabShop and BK Connect support the following waveforms:

- Single fixed sine (continuous or burst)
- Single swept sine
- Dual fixed sine
- Dual swept sine (Type 3160 only)
- Fixed sine plus swept sine
- Stepped sine (with steady-state response (SSR) analyzer)
- Random (continuous or burst)
- Pseudo-random (Type 3160 only)
- Pink- or white-noise (Type 3160 only)
- Periodic random
- User-defined, arbitrary waveforms can be streamed/downloaded

### Overload

Output voltages above  $10 \text{V}_{\text{peak}}$  or output currents above  $40 \text{mA}_{\text{peak}}$  are indicated as overloads by the circular LEDs on the output channels (alternating red/blue).

### Security

Output is automatically shut down in cases of heavy overload (shorted output) that could affect module functionality by drawing more current than available. The signal ramps up again when the overload is removed. An output channel is also automatically shut down (muted) in cases of power failure.

### Monitor Output (Type 3161 only)

An output signal is available on a BNC connector that allows you to monitor the input. The signal is taken after the high-pass filter but before the anti-aliasing filter. The signal is always referred to (chassis) ground. The specifications for this output are the same as the input channel. In the 31.6 V range, the signal is attenuated by 10 dB (3.16 $\times$ ). Charge signals are inverted.

### Auxiliary Channels (Type 3056 only)

Measure auxiliary, pseudo-DC parameters with up to eight low-frequency input channels that can be recorded along with the dynamic channels and used as logging or multi-buffer tags.

The eight auxiliary input channels are present on two 10-pin connectors, each of which is sampled 16 times per second, that is they have a 16 Hz sampling rate. The channels are single-ended and have a single 10 V input range. Auxiliary channel settings and data are accessed via Automation (formerly known as OLE Automation).

Fig. 6 10-pin LEMO® auxiliary connector

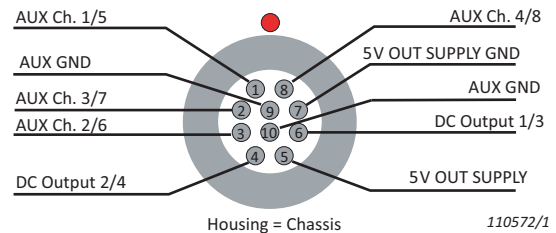

Typical applications include:

- Automotive: intake pressure, thermocouples, throttle position, vehicle acceleration/braking
- Industrial: process parameters (temperature, pressure and control position)
- Production line testing: programmable logic controller (PLC) parameters, environmental conditions (temperature, barometric pressure)
- Pass-by testing: environmental parameters
- Auxiliary data like temperature and wind speed available as time data or as z-axis tags
- Integration of auxiliary parameters with dynamic data such as FFT, order and CPB spectra

### Supported Accessories

Break-out Box ZH-0699, with  $2 \times 10$ -pin LEMO\* (M) connectors, is available as an accessory and provides BNC connectors for the eight auxiliary signals and four DC outputs.

Fig. 7 Break-out Box ZH-0699



130369

\* LEMO FGG.1B.310.CLAZ31

Auxiliary cable AO-0738-D-010, 2 × 10-pin LEMO\* (M) to 8 × BNC (F) plus ground, is available as an accessory (input only). DC outputs require a custom cable or Break-out Box ZH-0699.

Fig. 8 Auxiliary cable AO-0738-D-010

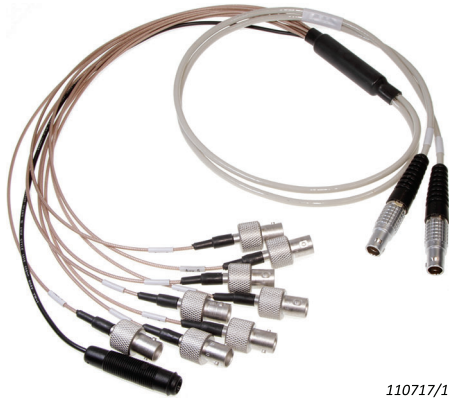

DC Output Channels (Type 3056 only)

The four programmable DC outputs of Type 3056 (Fig. 6) are open-drain outputs that are able to sink 100 mA from an external supply of up to 24 V, sufficient for a relay. DC output without an external supply is 5 V, max. 50 mA. DC outputs require a custom cable.

High-speed Tacho Channels (Type 3056 only)

Of the four input channels on Type 3056, channels 1 and 3 can be independently configured to support high-speed tacho signals needed to perform high-precision angle domain analysis on fast-rotating machinery and combustion engines. Channels 2 and 4 can be independently configured for tacho reference signals. The high-speed tacho signals are typically supplied from angle encoders.

Type 3056 supports self-powered, externally powered and CCLD powered tachometers including Type 2981. Power supply for legacy MM-0012 and MM-0024 is not available.

Note that BK Connect Time Data Recorder supports only two high-speed tacho channels (one tacho channel and one tacho [angle] reference channel). For full support of four high-speed tacho channels, use PULSE LabShop.

	PULSE LABSHOP	BK CONNECT TIME DATA RECORDER
Ch. 1	High-speed tacho signal or normal input	High-speed tacho signal or normal input
Ch. 2	High-speed tacho ref. or normal input	High-speed tacho ref. or normal input
Ch. 3	High-speed tacho signal or normal input	Normal input
Ch. 4	High-speed tacho ref. or normal input	Normal input

Fig. 9 BK Connect Angle Domain Analysis Type 8440 (BP 2576) uses angle profile and key phasor information from high-speed tachometer and tachometer reference signals for angle calculation and subsequent cycle extraction for applications such as crank angle analysis

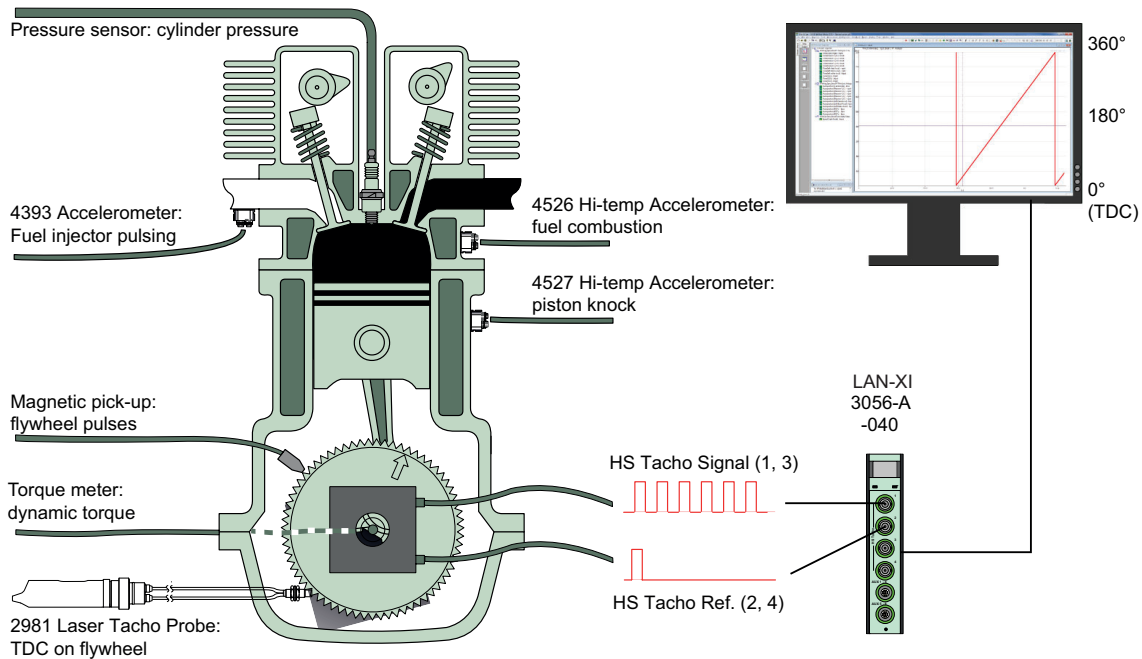

130338

### Technical Support

With a Software Maintenance and Support Agreement you get technical support via telephone, email or web conference\*. You get direct contact with a knowledgeable and dedicated engineer to help you with:

- Configuration, setup and preparation of projects
- Immediate questions during installation or measurements
- Advice and assistance on post-processing tasks

### Accredited Calibration

We recommend you have your system calibrated regularly (annually or every second year) in order to:

- Know if values have shifted in one of the channels
- Prove measurement traceability
- Prove calibration of the entire measurement chain

Your calibration certificate contains measurement results as well as associated uncertainties. With accredited calibration services from HBK, you have proof that calibration has been performed according to quality requirements in ISO 17025. To start the measurement history from day one, we recommend that you order accredited calibration with all new instruments.

### Hardware Maintenance

Local HBK staff and skilled technicians at the manufacturing site can make sure that your instruments are performing to specifications to maximize the uptime of your instruments by:

- Conformance testing if you need manufacturer's proof that your hardware performs according to specifications
- Repairing or replacing components in your hardware

Battery Module Type 2831-A is designed for many years of service. As with all rechargeable batteries, the service life will depend on usage, and the Li-ion cells will likely reach the end of their service life before the other components in the battery module. Type 2831-A can be replaced or refurbished without returning the entire system. Maintenance is more cost effective than purchasing a new battery, reduces waste and ensures that the cells are disposed of in an environmentally friendly way.

---

\* Check with your local HBK office for service availability in your area.

### Service Agreement

With a Service Agreement you can save both time and money. The value of a Service Agreement lies in a combination of the following:

- Assurance that the time your instrument is away for service is minimized
- Attractive total service price

You can combine a range of services in one agreement over several years. You get priority at the time you need service and predictable maintenance budget. With planned service your instrument is available at the time you set up for measurements and you have proof of correct data.

Should the technician, during calibration, detect the need for repair or replacement, this will be performed while the instrument is with HBK, if covered by the service agreement. You do not have to be without your instrument several times. There is no delay in communication to decide what should happen with the instrument – and no large surprises to your budget.

Examples of what a Service Agreement can contain:

- Simultaneous maintenance and calibration support
- Multiple calibrations – to give the most favourable price
- Priority calibration
- Priority repair or replacement
- Extension of manufacturer's warranty

TYPES 3660-D-100, 3660-C-100, 3660-A-200, 3050, 3052, 3053, 3056, 3160, 3161 AND 2831-A

		The CE marking is the manufacturer's declaration that the product meets the requirements of the applicable EU directives RCM mark indicates compliance with applicable ACMA technical standards – that is, for telecommunications, radio communications, EMC and EME China RoHS mark indicates compliance with administrative measures on the control of pollution caused by electronic information products according to the Ministry of Information Industries of the People's Republic of China WEEE mark indicates compliance with the EU WEEE Directive
Safety	Modules and Frames	EN/IEC 61010-1 and ANSI/UL 61010-1: Safety requirements for electrical equipment for measurement, control and laboratory use Type 2831-A meets IEC 62133-2:2017 and IEC 62133-2:2017/AMD1:2021: Amendment 1- Secondary cells and batteries containing alkaline or other non-acid electrolytes - safety requirements for portable sealed secondary cells, and for batteries made from them, for use in portable applications - Part 2: Lithium systems
	Wireless Frame	EN/IEC 60950-1: Information technology equipment – Safety part 1: General requirements
Health	Wireless Frame	EN/IEC 62311: Assessment of electronic and electrical equipment related to human exposure restrictions for electromagnetic fields (0 Hz to 300 GHz)
EMC Emission	Modules	EN/IEC 61326: Electrical equipment for measurement, control and laboratory use – EMC requirements EN/IEC 61000-6-3: Generic emission standard for residential, commercial and light industrial environments CISPR 32: Electromagnetic compatibility of multimedia equipment – emission requirements. Class B
	Frames	EN/IEC 61326: Electrical equipment for measurement, control and laboratory use – EMC requirements EN/IEC 61000-6-4: Generic emission standard for industrial environments CISPR 32: Electromagnetic compatibility of multimedia equipment – emission requirements. Class A
	Wireless Frame	EN/IEC 61326: Electrical equipment for measurement, control and laboratory use – EMC requirements EN/IEC 55032: Electromagnetic compatibility of multimedia equipment Q – Emission requirements EN 301 489-1 V2.2.0: For radio equipment and services; Part 1: Common technical requirements EN 301 489-17 V3.2.0: For radio equipment and services; Part 17: Specific conditions for broadband data transmission systems
EMC Immunity	Modules and Frames	EN/IEC 61326: Electrical equipment for measurement, control and laboratory use – EMC requirements EN/IEC 61000-6-1: Generic standards – Immunity for residential, commercial and light industrial environments EN/IEC 61000-6-2: Generic standards – Immunity for industrial environments <b>Note:</b> The frames and modules fulfil the immunity standards, except: • Type 3660-C-100 meets EN 61000-4-2 at ±4 kV air discharge and EN 61000-4-5 surge 1.5 kV line-earth • Type 3660-D-100 meets EN 61000-4-2 at ±1 kV air and conduct discharge and EN 61000-4-5 surge ±1.5 kV line-earth • All modules meet ESD performance with criterion C
	Wireless Frame	EN/IEC 55035: Electromagnetic compatibility of multimedia equipment – Immunity requirements
Radio Spectrum	Wireless Frame	EN 300 328 V2.2.0: Wideband transmission systems
Temperature	All Types	IEC 60068-2-1: Environmental testing – Cold IEC 60068-2-2: Environmental testing – Heat Ambient Operating Temperature: -10 to +55 °C (14 to 131 °F) Storage Temperature: -25 to +70 °C (-13 to +158 °F)
Humidity	All Types	IEC 60068-2-78: Damp Heat: 93% RH (non-condensing at 40 °C (104 °F))
Mechanical (non-operating)	Modules	IEC 60068-2-6: Vibration: 0.3 mm, 2 g, 10 – 500 Hz IEC 60068-2-27: Shock: 100 g IEC 60068-2-29: Bump: 1000 bumps at: 25 g
	Frames	IEC 60068-2-6: Vibration: 0.3 mm, 2 g, 10 – 500 Hz IEC 60068-2-27: Shock: • Type 3660-C-100: 100 g • Type 3660-D-100: 50 g IEC 60068-2-29: Bump: • Type 3660-C-100: 1000 bumps at: 25 g empty, 15 g loaded with modules • Type 3660-D-100: 1000 bumps at: 25 g loaded with modules
Enclosure	Modules and Frames	IEC 60529: Protection provided by enclosures: • Types 3660-C-100 and 3660-D-100: IP 20 • Types 3050, 3052, 3053, 3160, 3161, 2831-A: IP 31
Magnetic Field	All Types	EN/IEC 61000-4-8: 30 A/m

Notes:

- The above is only guaranteed using accessories listed in this document
- For environmental specifications and compliance with standards for PCs, see the specifications given by their respective manufacturers

EFFECT OF RADIATED AND CONDUCTED RF, MAGNETIC FIELD AND VIBRATION

Radiated RF: 80 – 2700 MHz, 80% AM 1 kHz, 10 V/m

Conducted RF: 0.15 – 80 MHz, 80% AM 1 kHz, 10 V

Magnetic Field: 30 A/m, 50 Hz

Vibration: 5 – 500 Hz, 12.7 mm, 15 m/s<sup>2</sup>

Note: Input measured with shorted input. All values are root mean square (rms). Conducted RF immunity on all channels is only guaranteed using an external connection from measuring ground to chassis terminal

INPUT/OUTPUT	RADIATED RF	CONDUCTED RF	MAGNETIC FIELD	VIBRATION
Direct/CCLD	<250 µV	<300 µV	<4 µV	<80 µV
Preamplifier*	<250 µV	<50 µV	<8 µV	<80 µV
Charge (1 nF transducer) <sup>†</sup>	<10 pC	<3 pC	<0.3 pC	<3 pC
Generator	<1 mV	<50 µV	<2 µV	<5 µV

\* Not applicable for Type 3053

† Valid for Type 3161-A-011

Compliance with Standards and Specifications for Module Types 3057 and 3058

Visit [www.hbkworld.com](http://www.hbkworld.com) to view product data for LAN-XI Module Types 3057 and 3058, including information about compliance with standards and specifications.

**POWER REQUIREMENTS**

- Mains:** Wide-range input 90–264 V AC, 47–63 Hz  
**External Mains Power Connector:** Connector type C14 according to IEC/EN 60320–1  
**DC Input:** 11 – 32 V DC  
**Connector:** 4-pin XLR plug  
**Power Consumption (Type 3660-C-100):**
- Starts with 19 W if equipped with 1 LAN-XI module
  - Rises to 70 W if equipped with 5 LAN-XI modules
  - Maximum power consumption: 90 W
- Power Consumption (Type 3660-D-100):**
- Starts with 25 W if equipped with 1 LAN-XI module
  - Rises to 150 W if equipped with 11 LAN-XI modules
  - Maximum power consumption: 200 W

**BATTERY**

- Charging** (serial numbers <110000):
- Mains (AC)
- Charging** (serial numbers ≥110000):
- Mains (AC)
  - External DC (>12.5 V)
  - 12 V car with engine (generator) running
- Charging Time:**
- Mains: 3 hours to fully charge one or two Type 2831-A batteries

**DC OUTPUT**

- +12 V ±1.0 V; max. 1 A (with current protection)  
**Connector:** EIAJ-05 (pin Ø1.4 mm, outer Ø6.5 mm)

Specifications – Wireless Frame Type 3660-A-20x

Wireless Specifications

**ETHERNET**

- WAN/LAN × 1, RJ-45 for 10/100 BaseT
- Ethernet and 802.3 with max. 10/100 Mbps bit rate and auto cross-over function (MDI-X)

**POWER ADAPTOR**

- AC Input:** 100 – 240 V (50 – 60 Hz)  
**DC Output:** 5 V with max. 1 A current

**OPERATING FREQUENCY**

- 2.4 GHz

**DATA RATE**

- IEEE 802.11n: up to 150 Mbps
- IEEE 802.11g: 6-54 Mbps
- IEEE 802.11b: 1-11 Mbps

**ENCRYPTION/AUTHENTICATION**

Supports 64/128-bit WEP, WPA-PSK, WPA2-PSK

**RANGE**

The range is similar to a standard WLAN unit, typically from 10 to 50 m (33 to 164 ft), depending on the environment and the number of other WLAN transmitters in the area, for example, smartphones, Wi-Fi®, etc.

**GPS**

**Connector:** SMA

**LAN**

Two connectors type RJ-45 8/8, optionally Neutrik® etherCON NE8MC1. Left connector for connection to PC. Right connector includes PoE (IEEE 802.3af) power and is for connection to accessories like PoE cameras or wireless access points (WAP). On Type 3660-C-100, PoE power can be selected on either the first or the second connector

**ACOUSTIC NOISE EMISSION**

	TYPE 3660-D-100 DB LW, A-WEIGHTED	TYPE 3660-C-100 DB LW, A-WEIGHTED
Fan Off	10	5
Normal (22 °C)	32	37
Maximum	48	51

**DIMENSIONS**

- Height:** 177.8 mm (7.0 in)  
**Depth:** 420.4 mm (16.5 in)  
**Width:**
- Type 3660-C-100: 224.5 mm (8.8 in)
  - Type 3660-D-100: 388.5 mm (15.3 in)
- Weight** (frame with mains power supply, etc.):
- Type 3660-C-100: 5.3 kg (11.7 lb)
  - Type 3660-D-100: 7 kg (15.4 lb)

**MANAGEMENT**

- DHCP server
  - Web-based administration
  - System event log
  - Firmware upgrade
  - Save/restore configuration file
- Power Requirements (Type 2831-A)
- DC Input:** 10 – 32 V DC  
**Connector:** LEMO®  
 Power Consumption (Type 3660-A): ≤12 W (incl. LAN-XI module)

**BATTERY CHARGING TIME**

- With Battery Module set to Active:** 3 hours with ZG-0880 mains charger, 4 hours with ZG-0858 DC/in-vehicle charger  
**Battery Lifetime:** Approximately 500 cycles

Hardware Specifications

**EXTERNAL CASE – DIMENSIONS AND WEIGHT**

- Length:** 48 mm (1.89 in)  
**Width:** 53 mm (2.09 in)  
**Height:** 131 mm (5.16 in)  
**Weight:** 0.29 kg (0.64 lb)

**POWER REQUIREMENTS**

DC Input: 10 – 32 V DC

Connector: LEMO coax., FFA.00.113, ground on shield

Power Consumption:

- DC Input: < 15 W
- Supply via PoE: According to IEEE 802.3af, max. cable length is 100 m (328 ft)
- Typical Operating Time on Battery Type 2831-A:
  - >7 hours with single module
  - >40 minutes in Type 3660-D-100 frame (up to two batteries in Type 3660-D-100)

**Temperature Protection:** Temperature sensor limits module’s internal temperature to 80 °C (176 °F). If temperature exceeds limit, system will automatically enable fan in LAN-XI frame or shut down module outside frame

**DIMENSIONS AND WEIGHT**

Height: 132.6 mm (5.22 in)

Width: 27.5 mm (1.08 in)

Depth: 248 mm (9.76 in)

Weight: 750 g (1.65 lb)

**LAN**

Connector type RJ-45

Statement of Volatility

A statement or letter of volatility outlines the volatility of the memory on a device. Memory is volatile if it is not retained when the device is powered off, and non-volatile if it is retained when the device is powered off. This information can be used to ensure that security requirements are met and as a guide for handling the device.

Table 1 is an overview of the types of memory used in LAN-XI modules, including if the memory is volatile or non-volatile.

**MEMORY**

- Modules have one power board, one analogue board and one digital board
- All modules are based on the same digital board
- The analogue board can only store small binary images for the complex programmable logic devices (CPLDs)/small field programmable gate arrays (FPGAs). If the data is overwritten, it does not work
- The power board has no memory circuits
- The system is for sound and vibration measurements. Audio can be recorded but only using attached devices; there are no built-in microphones
- An SD card for measurement data may be inserted and used. This is the only built-in place to store user data

Table 1 Data storage and data volatility

	VOLATILE MEMORY				NON-VOLATILE MEMORY		
	MAIN MEMORY	MICRO-PROCESSOR CACHE	FIRMWARE MEMORY	GRAPHICS MEMORY	CMOS MEMORY	DETACHABLE FRONT PANEL MEMORY	CPLD/FPGA MEMORY
Size	128 Mbyte (ARM) + 16 Mbyte (DSP)	256 kbyte	64 Mbyte	256 byte	8 kbyte	8 kbyte	Small, varies by module
Type	DRAM	Cache	FLASH PROM	CPU built-in RAM	EEPROM	EEPROM	Flash
Purpose	System memory	Level 1 cache	System software	Text buffer	Very basic configuration	Front panel information*	For gate arrays
Can data be written to the memory under normal operating conditions?	Yes	No	No†	No	No	No	No†
Is data retained when powered off?	No	No	No	No	Yes IP address, synch mode, etc.	Yes	Yes
How is data input to this memory?	Via ARM CPU and Motorola DSP	Transient data from main memory	Vendor-supplied firmware download	Normal operation	ARM-based driver routine	At the factory only	Vendor-supplied firmware download
Memory write protection	Not applicable	Not applicable	Vendor-supplied firmware only	Not applicable	Not applicable	Not applicable	Vendor-supplied firmware only

\* The small-memory internal circuit (IC) contains the front panel ID, version number and image. The image is very low-resolution and assures that the front panel can be displayed while using versions of BK Connect that are older than the front panel

† Memory is written to when the firmware is updated, which is a regular procedure. There are two firmware versions: a factory version for backup and a version for the user. The factory version can only be written at the factory. The version for the user is loaded via a special program (supplied by HBK) or via the module’s web-based interface. The firmware is not designed to store measurement data, data cannot be written to this memory during normal operation.

**INPUT CHANNELS (DYN-X) – TYPES 3050, 3052 AND 3160**

Frequency Range		DC to 51.2 kHz (Types 3050 and 3160) DC to 102.4 kHz (Type 3052) Lower frequency range can be set in PULSE LabShop, BK Connect				
Sampling Rate		Types 3050, 3160: 131 ksamples/s; Type 3052: 262 ksamples/s				
A/D Conversion		2 × 24 bit				
Data Transfer		24 bit				
Input Voltage Range		10 V <sub>peak</sub> Extended Range: 31.6 V <sub>peak</sub>				
Input Signal Coupling		Differential		Signal ground is 'floating' (1 MΩ re: chassis)		
		Single-ended		Signal ground is connected to chassis ('Grounded')		
Input Impedance		Direct, Microphone: 1 MΩ    < 300 pF				
		CCLD: >100 kΩ    < 300 pF				
Absolute Maximum Input		±60 V <sub>peak</sub> without damage				
High-pass Filters		- 0.1 DB *	-10% @ **	-3 DB @ **	SLOPE	
* Defined as the lower frequency, f <sub>L</sub> , for guaranteed fulfilment of -0.1 dB accuracy in 10 V <sub>peak</sub> range	0.1 Hz – 10% analogue high-pass filter	0.5 Hz	0.1 Hz	0.05 Hz	-20 dB/dec.	
	0.7 Hz – 0.1 dB digital high-pass filter	0.7 Hz	0.15 Hz	0.073 Hz		
** Defined as the nominal -10%/3 dB filter frequency	1 Hz – 10% digital high-pass filter	5 Hz	1.0 Hz	0.5 Hz	-20 dB/dec.	
	7 Hz – 0.1 dB digital high-pass filter	7 Hz	1.45 Hz	0.707 Hz		
	22.4 Hz – 0.1 dB analogue high-pass filter	22.4 Hz	15.8 Hz	12.5 Hz	-60 dB/dec.	
	Intensity filter (analogue)	115 Hz	23.00 Hz	11.5 Hz	-20 dB/dec.	
Absolute Amplitude Precision, 1 kHz, 1 V <sub>input</sub>		±0.05 dB, typ. ±0.01 dB				
Amplitude Linearity (linearity in one range)		0 to 80 dB below full scale		±0.05 dB, typ. ±0.01 dB		
		80 to 100 dB below full scale		±0.2 dB, typ. ±0.02 dB		
		100 to 120 dB below full scale		typ. ±0.02 dB		
		120 to 140 dB below full scale		typ. ±0.02 dB		
		140 to 160 dB below full scale		typ. ±1 dB		
Overall Frequency Response re 1 kHz, from lower limit f <sub>L</sub> to upper limit f <sub>U</sub> f <sub>L</sub> is defined as the lower frequency for guaranteed fulfilment of -0.1 dB accuracy in 10 V <sub>peak</sub> range (see under High-pass Filters) f <sub>U</sub> is defined as the chosen frequency span. DC (f <sub>L</sub> = 0)		±0.1 dB ±0.3 dB in 31.6 V range				
Noise (Types 3050 G1 and 3160)		INPUT RANGE	GUARANTEED		TYPICAL	
			LIN*	1 KHZ	LIN*	1 KHZ
* Measured lin. 10 Hz to 25.6 kHz or lin. 10 Hz to 51.2 kHz: (Input terminated by 50 Ω or less)	Signal level <316 mV <sub>peak</sub> 10 Hz to 25.6 kHz 10 Hz to 51.2 kHz	10 V <sub>peak</sub>	<4 μV <sub>rms</sub> <13 μV <sub>rms</sub>	<25 nV <sub>rms</sub> /√Hz	<3 μV <sub>rms</sub> <10 μV <sub>rms</sub>	<19 nV <sub>rms</sub> /√Hz
	Signal level >316 mV <sub>peak</sub> 10 Hz to 25.6 kHz 10 Hz to 51.2 kHz	10 V <sub>peak</sub>	<60 μV <sub>rms</sub> <350 μV <sub>rms</sub>	<375 nV <sub>rms</sub> /√Hz	<50 μV <sub>rms</sub> <250 μV <sub>rms</sub>	<313 nV <sub>rms</sub> /√Hz
	Signal level <1 V <sub>peak</sub> 10 Hz to 25.6 kHz 10 Hz to 51.2 kHz	31.6 V <sub>peak</sub>	<20 μV <sub>rms</sub> <45 μV <sub>rms</sub>	<125 nV <sub>rms</sub> /√Hz	<15 μV <sub>rms</sub> <35 μV <sub>rms</sub>	<95 nV <sub>rms</sub> /√Hz
	Signal level >1 V <sub>peak</sub> 10 Hz to 25.6 kHz 10 Hz to 51.2 kHz	31.6 V <sub>peak</sub>	<200 μV <sub>rms</sub> <1200 μV <sub>rms</sub>	<1250 nV <sub>rms</sub> /√Hz	<150 μV <sub>rms</sub> <800 μV <sub>rms</sub>	<950 nV <sub>rms</sub> /√Hz
Noise (Type 3050 G2)		INPUT RANGE	GUARANTEED		TYPICAL	
			LIN	@ 1 KHZ	LIN	@ 1 KHZ
* Measured lin. 10 Hz to 51.2 kHz: (Input terminated by 50 Ω or less)	Signal level <316 mV <sub>peak</sub> 10 Hz to 25.6 kHz 10 Hz to 51.2 kHz	10 V <sub>peak</sub>	<4 μV <sub>rms</sub> <6 μV <sub>rms</sub>	<25 nV <sub>rms</sub> /√Hz	<3 μV <sub>rms</sub> <4.5 μV <sub>rms</sub>	<19 nV <sub>rms</sub> /√Hz
	Signal level >316 mV <sub>peak</sub> 10 Hz to 25.6 kHz 10 Hz to 51.2 kHz	10 V <sub>peak</sub>	<60 μV <sub>rms</sub> <85 μV <sub>rms</sub>	<375 nV <sub>rms</sub> /√Hz	<50 μV <sub>rms</sub> <71 μV <sub>rms</sub>	<313 nV <sub>rms</sub> /√Hz
	Signal level <1 V <sub>peak</sub> 10 Hz to 25.6 kHz 10 Hz to 51.2 kHz	31.6 V <sub>peak</sub>	<20 μV <sub>rms</sub> <29 μV <sub>rms</sub>	<125 nV <sub>rms</sub> /√Hz	<15 μV <sub>rms</sub> <22 μV <sub>rms</sub>	<95 nV <sub>rms</sub> /√Hz
	Signal level >1 V <sub>peak</sub> 10 Hz to 25.6 kHz 10 Hz to 51.2 kHz	31.6 V <sub>peak</sub>	<200 μV <sub>rms</sub> <285 μV <sub>rms</sub>	<1250 nV <sub>rms</sub> /√Hz	<150 μV <sub>rms</sub> <215 μV <sub>rms</sub>	<950 nV <sub>rms</sub> /√Hz

**INPUT CHANNELS (DYN-X) – TYPES 3050, 3052 AND 3160**

Noise (Type 3052)		INPUT RANGE	GUARANTEED		TYPICAL	
			LIN*	1 KHZ	LIN*	1 KHZ
* Measured lin. 10 Hz to 51.2 kHz or lin. 10 Hz to 102.4 kHz: (Input terminated by 50 Ω or less)	Signal level <316 mV <sub>peak</sub> 10 Hz to 25.6 kHz 10 Hz to 51.2 kHz 10 Hz to 102.4 kHz	10 V <sub>peak</sub>	<4 μV <sub>rms</sub> <6 μV <sub>rms</sub> <8 μV <sub>rms</sub>	<25 nV <sub>rms</sub> /√Hz	<3 μV <sub>rms</sub> <4.5 μV <sub>rms</sub> <6 μV <sub>rms</sub>	<19 nV <sub>rms</sub> /√Hz
	Signal level >316 mV <sub>peak</sub> 10 Hz to 25.6 kHz 10 Hz to 51.2 kHz 10 Hz to 102.4 kHz	10 V <sub>peak</sub>	<60 μV <sub>rms</sub> <85 μV <sub>rms</sub> <120 μV <sub>rms</sub>	<375 nV <sub>rms</sub> /√Hz	<50 μV <sub>rms</sub> <71 μV <sub>rms</sub> <100 μV <sub>rms</sub>	<313 nV <sub>rms</sub> /√Hz
	Signal level <1 V <sub>peak</sub> 10 Hz to 25.6 kHz 10 Hz to 51.2 kHz 10 Hz to 102.4 kHz	31.6 V <sub>peak</sub>	<20 μV <sub>rms</sub> <29 μV <sub>rms</sub> <40 μV <sub>rms</sub>	<125 nV <sub>rms</sub> /√Hz	<15 μV <sub>rms</sub> <22 μV <sub>rms</sub> <30 μV <sub>rms</sub>	<95 nV <sub>rms</sub> /√Hz
	Signal level >1 V <sub>peak</sub> 10 Hz to 25.6 kHz 10 Hz to 51.2 kHz 10 Hz to 102.4 kHz	31.6 V <sub>peak</sub>	<200 μV <sub>rms</sub> <285 μV <sub>rms</sub> <400 μV <sub>rms</sub>	<1250 nV <sub>rms</sub> /√Hz	<150 μV <sub>rms</sub> <215 μV <sub>rms</sub> <300 μV <sub>rms</sub>	<950 nV <sub>rms</sub> /√Hz
<b>Spurious-free Dynamic Range re Full-scale Input</b> (Input terminated by 50 Ω or less) Spurious-free Dynamic Range is defined as the ratio of the rms full-scale amplitude to the rms value of the largest spurious spectral component (non-harmonic)		INPUT RANGE	TYPICAL			
		10 V <sub>peak</sub>	160 dB			
		31.6 V <sub>peak</sub>	140 dB			
<b>DC Offset re Full Scale</b> Measured after automatic DC compensation at current temperature when changing from AC to DC coupling or changing input range when DC coupled	Model	GUARANTEED	TYPICAL			
	Types 3050 and 3160	< -90 dB	-100 dB			
	Type 3052	< -60 dB	-80 dB			
<b>Harmonic Distortion (all harmonics)</b>		GUARANTEED	TYPICAL			
		-80 dB (-60 dB in 31.6 V range)	-100 dB @ 1 kHz (-80 dB @ 1 kHz in 31.6 V range)			
<b>Crosstalk</b> Between any two channels of a module or between any two channels in different modules, in 10 V input range only		FREQUENCY RANGE	GUARANTEED	TYPICAL		
		0 – 51.2 kHz (Types 3050 or 3160) 0 – 100.4 kHz (Type 3052)	-100 dB (-90 dB in 31.6 V range)	-140 dB		
<b>Channel-to-channel Match</b> (10 V <sub>peak</sub> input range)		GUARANTEED	TYPICAL			
Maximum Gain Difference f <sub>L</sub> is defined as the -0.1 dB frequency of the high-pass filter	Types 3050 and 3160	0.2 dB from lower frequency limit, f <sub>L</sub> , to 51.2 kHz (0.4 dB at -10% filter frequency)	±0.05 dB			
	Type 3052	0.1 dB from lower frequency limit, f <sub>L</sub> , to 102.4 kHz (0.4 dB at -10% filter frequency)	±0.01 dB			
Types 3050 and 3160 Maximum Phase Difference f <sub>L</sub> is defined as the -0.1 dB frequency of the high-pass filter						
Type 3052 Maximum Phase Difference f <sub>L</sub> is defined as the -0.1 dB frequency of the high-pass filter						

**INPUT CHANNELS (DYN-X) – TYPES 3050, 3052 AND 3160**

Channel-to-channel Match (31.6 V <sub>peak</sub> input range)	Maximum Gain Difference	Types 3050 and 3160	0.6 dB from lower frequency limit, f <sub>L</sub> , to 51.2 kHz (1 dB at –10% filter frequency)
		Type 3052	0.6 dB from lower frequency limit, f <sub>L</sub> , to 102.4 kHz (1 dB at –10% filter frequency)
	Maximum Phase Difference (within one frame)	Types 3050 and 3160	4° from lower frequency limit, f <sub>L</sub> , to 51.2 kHz
		Type 3052	4° from lower frequency limit, f <sub>L</sub> , to 102.4 kHz
Sound Intensity Phase Match (only for using intensity filter and in 10 V <sub>peak</sub> input range) All channels matched	Frequency Range	<b>GUARANTEED PHASE MATCH</b>	<b>TYPICAL PHASE MATCH</b>
	50 – 250 Hz	±0.017°	±0.005°
	250 Hz – 2.5 kHz	0.017° × (f/250)	±0.005°
	2.5 – 6.4 kHz	±0.17°	±0.08°
Common Mode Rejection in 10 V <sub>peak</sub> input range Values for 31.6 V <sub>peak</sub> range are 10 dB lower		<b>GUARANTEED</b>	<b>TYPICAL</b>
	0 – 120 Hz	70 dB	80 dB
	120 Hz – 1 kHz	55 dB	60 dB
	1 – 51.2 kHz	30 dB	40 dB
	51.2 – 102.4 kHz (Type 3052 only)	30 dB	40 dB
Absolute Max. Common Mode Voltage		±5 V <sub>peak</sub> without damage	
		±4 V <sub>peak</sub> without clipping (Types 3050, 3160) ±3 V <sub>peak</sub> without clipping (Type 3052)	
		If common mode voltage exceeds the max. value, care must be taken to limit the signal ground current in order to prevent damage. Max. is 100 mA. The instrument will limit the voltage to the stated max. 'without damage' common mode value	
Anti-aliasing Filter At least 90 dB attenuation of those frequencies which can cause aliasing	Filter Type	3rd order Butterworth	
	–0.1 dB @	51.2 kHz or 102.4 kHz (Type 3052)	
	–3 dB @	128 kHz or 256 kHz (Type 3052)	
	Slope	–18 dB/octave	
Supply for Microphone Preamplifiers		±14.0 V, max. 100 mA per channel (max. 100 mA total/module)	
Supply for Microphone Polarization		200 V ±1 V, or 0 V (set per channel)	
Supply for CCLD	Types 3050 G1, 3052 and 3160	4 to 5 mA from 24 V source, option to DC-couple CCLD power supply	
	Type 3050 G2	3.6 mA from 24 V source	
Tacho Supply		CCLD for Type 2981 (Power supply for legacy Types MM-0012 and MM-0024 not available)	
Analogue Special Functions		<b>Microphone Charge Injection Calibration (CIC):</b> All modules with 7-pin LEMO support CIC via dedicated application software and Automation interface <b>Transducers:</b> Supports IEEE 1451.4-capable transducers with standardized TEDS (up to 100 m (328 ft) cable length)	
Overload Detection		<b>Signal Overload:</b> Adjustable detection level ±1 V <sub>peak</sub> to ±10 V <sub>peak</sub> . Default level ±10 V <sub>peak</sub> (CCLD mode ±7 V <sub>peak</sub> ) (31.6 V range: ±31.6 V) can be set in Transducer Database (PULSE LabShop, BK Connect) <b>CCLD Overload:</b> Detection of cable break or short-circuit + detection of CCLD transducer working point fault. Detection level: +2 V/20 V <b>Microphone Preamplifier Overload:</b> Detection of microphone preamplifier current consumption too high or too low. Detection level default 10 mA/1 mA Adjustable detection level 1 to 20 mA or 100 mA if disabled <b>Common Mode Voltage Overload:</b> Detection level: ±3.0 V	
Protection		If signal input level exceeds the measuring range significantly, the input will go into protection mode until the signal goes below the detection level again for at least 0.5 s. While in protection mode, the input is partly switched off and the input impedance is greatly increased. (The measured value will be strongly attenuated but still detectable.) In DC mode –10 V <sub>peak</sub> range, the detection limit is ±12 V. In all other measuring modes (except CCLD), the limit is ±50 V <sub>peak</sub> including DC component or ±12 V <sub>peak</sub> AC. In CCLD mode, the limit is +50/–2 V <sub>peak</sub> including DC component or ±12 V <sub>peak</sub> AC. In the 31.6 V range, the limit is ±50 V <sub>peak</sub> .	

**OUTPUT CHANNELS – TYPE 3160**

Output Connector	2 × BNC
Output Coupling	DC
Signal Ground Coupling	Floating or grounded to chassis
D/A Conversion	24 bit
DC Offset (DC Value set to 0 V)	≤1 mV auto-adjusted by loopback (<–80 dB re full scale)
Output Voltage Range (DC)	0 to ±10 V ±0.5% of requested value
Output Voltage Range (AC)	10 μV <sub>peak</sub> – 10 V <sub>peak</sub>
Output Impedance	50 Ω
Output Load	Max. 40 mA <sub>peak</sub>

## OUTPUT CHANNELS – TYPE 3160

Frequency Range	0 – 51.2 kHz		
Frequency Response re 1 kHz	±0.1 dB, 1 mHz to 51.2 kHz		
Frequency Accuracy	0.00025%		
Frequency Resolution	1 mHz (defined in PULSE LabShop, BK Connect)		
Phase Resolution	100 mdegrees (defined in PULSE LabShop, BK Connect)		
Phase Deviation Between Channels	<20 mdegrees for frequencies below 1 kHz*		
Waveform	Software determined arbitrary waveforms up to 2 Msamples Waveforms available in PULSE LabShop, BK Connect: Single fixed sine (continuous or burst), single swept sine, dual fixed sine, dual swept sine, fixed sine plus swept sine, stepped sine (with SSR analyzer), random (continuous or burst), pseudo-random, periodic random User-defined, arbitrary waveforms up to 102.4 kHz can be streamed or downloaded; for 204.8 kHz bandwidth the length is limited to 1 Msample.		
Amplitude Linearity @ 1 kHz	±0.1 dB	<b>GUARANTEED</b> 0 – 100 dB below 7 V <sub>rms</sub>	<b>TYPICAL</b> 0 – 110 dB below 7 V <sub>rms</sub>
Noise μV <sub>rms</sub> (nV/√Hz) in 50 kHz bandwidth	up to 316 mV <sub>peak</sub>	<b>GUARANTEED</b> 1 μV <sub>rms</sub> (4.4 nV/√Hz)	<b>TYPICAL</b> 0.5 μV <sub>rms</sub> (2.2 nV/√Hz)
	up to 10 V <sub>peak</sub>	10 μV <sub>rms</sub> (44 nV/√Hz)	5 μV <sub>rms</sub> (22 nV/√Hz)
Harmonic Distortion Products	0 – 51.2 kHz	< –80 dB re full range output	
Spurious In Band (non-harmonic)	0 – 51.2 kHz	< –100 dB re full range output or 1 μV, whichever is greater	
Spurious Out of Band (non-harmonic)	Up to 1 MHz	< –80 dB re full range output	
Absolute Amplitude Precision	@ 23 °C, 1 kHz, 1 V <sub>rms</sub>	<b>GUARANTEED</b> ±0.05 dB	
Crosstalk Between output channels and between any output channel and any input channel terminated by less than 50 Ω (unloaded generator output)	0 – 51.2 kHz	<b>GUARANTEED</b> –120 dB	<b>TYPICAL</b> –130 dB
		<b>Guaranteed</b> 60 dB	
Common Mode Rejection	1 Hz – 1 kHz	60 dB	
Maximum Common Mode Voltage	5 V <sub>peak</sub> , DC – 80 MHz If common mode voltage exceeds the max. value, care must be taken to limit the signal ground current in order to prevent damage. Max. is 100 mA. The instrument will limit the voltage to the stated max. 'without damage' common mode value		
Reconstruction Filter	Sixth order Butterworth (–3 dB frequency = 120 kHz typically)		
Attenuation of Mirror Frequencies	>80 dB		
Overload Detection	Reported to PULSE LabShop and BK Connect; indicated by light rings on output connectors for output voltage above 11 V <sub>peak</sub> and output current above 40 mA <sub>peak</sub>		

\* Signal generators are not synchronized between LAN-XI and IDA<sup>e</sup> generator modules. This does not affect continuous signals (random, white- or pink-noise) but is not suitable for burst random signals and sine signals requiring phase control between generators.

## Channel Specifications – Module Type 3161

### DIRECT/MICROPHONE PREAMPLIFIER INPUT – TYPE 3161

Frequency Range	DC to 204.8 kHz Lower frequency range can be set in PULSE LabShop, BK Connect				
Sampling Rate	524 ksamples/s				
A/D Conversion	2 × 24 bit				
Data Transfer	24 bit				
Input Voltage Range	10 V <sub>peak</sub> Extended range: 31.6 V <sub>peak</sub>				
Input Signal Coupling	Differential	Signal ground is 'floating' (1 MΩ re: chassis)			
	Single-ended	Signal ground is connected to chassis ('Grounded')			
Input Impedance	Direct, Microphone: 1 MΩ    <300 pF				
	CCLD: >100 kΩ    <300 pF				
Absolute Maximum Input	±60 V <sub>peak</sub> without damage				
High-pass Filters * Defined as the lower frequency, f <sub>L</sub> , for guaranteed fulfilment of –0.1 dB accuracy in 10 V <sub>peak</sub> range ** Defined as the nominal –10%/3 dB filter frequency	0.1 Hz – 10% analogue high-pass filter	–0.1 DB *	–10% @ **	–3 DB @ **	SLOPE –20 dB/dec.
	7 Hz – 0.1 dB digital high-pass filter	0.5 Hz	0.1 Hz	0.05 Hz	–20 dB/dec.
	22.4 Hz – 0.1 dB analogue high-pass filter	7 Hz	1.45 Hz	0.707 Hz	–20 dB/dec.
Absolute Amplitude Precision, 1 kHz, 1 V <sub>input</sub>	22.4 Hz	15.8 Hz	12.5 Hz	–60 dB/dec.	±0.05 dB, typ. ±0.01 dB

**DIRECT/MICROPHONE PREAMPLIFIER INPUT – TYPE 3161**

<b>Amplitude Linearity</b> (linearity in one range)		0 to 80 dB below full scale	±0.05 dB, typ. ±0.01 dB			
		80 to 100 dB below full scale	±0.2 dB, typ. ±0.02 dB			
		100 to 120 dB below full scale	typ. ±0.02 dB			
		120 to 140 dB below full scale	typ. ±0.02 dB			
		140 to 160 dB below full scale	typ. ±1 dB			
<b>Overall Frequency Response</b> re 1 kHz, from lower limit $f_L$ to upper limit $f_U$ $f_L$ is defined as the lower frequency for guaranteed fulfilment of –0.1 dB accuracy in 10 $V_{peak}$ range (see under High-pass Filters) $f_U$ is defined as the chosen frequency span. DC ( $f_L = 0$ )			0 to 102.4 kHz: ±0.1 dB 0 to 204.8 kHz: ±0.25 dB ±0.3 dB in 31.6 V range			
<b>Noise</b>  (Input terminated by 50 Ω or less)		<b>INPUT RANGE</b>	<b>GUARANTEED</b>		<b>TYPICAL</b>	
			<b>LIN</b>	<b>@ 1 KHZ</b>	<b>LIN</b>	<b>@ 1 KHZ</b>
Signal level < 316 mV <sub>peak</sub> 10 Hz to 25.6 kHz 10 Hz to 51.2 kHz 10 Hz to 102.4 kHz 10 Hz to 204.8 kHz		10 V <sub>peak</sub>	< 4 μV <sub>rms</sub> < 6 μV <sub>rms</sub> < 8 μV <sub>rms</sub> < 12 μV <sub>rms</sub>	< 25 nV <sub>rms</sub> /√Hz	< 3 μV <sub>rms</sub> < 4.5 μV <sub>rms</sub> < 6 μV <sub>rms</sub> < 8.5 μV <sub>rms</sub>	< 19 nV <sub>rms</sub> /√Hz
Signal level > 316 mV <sub>peak</sub> 10 Hz to 25.6 kHz 10 Hz to 51.2 kHz 10 Hz to 102.4 kHz 10 Hz to 204.8 kHz		10 V <sub>peak</sub>	< 60 μV <sub>rms</sub> < 85 μV <sub>rms</sub> < 120 μV <sub>rms</sub> < 170 μV <sub>rms</sub>	< 375 nV <sub>rms</sub> /√Hz	< 50 μV <sub>rms</sub> < 71 μV <sub>rms</sub> < 100 μV <sub>rms</sub> < 150 μV <sub>rms</sub>	< 313 nV <sub>rms</sub> /√Hz
Signal level < 1 V <sub>peak</sub> 10 Hz to 25.6 kHz 10 Hz to 51.2 kHz 10 Hz to 102.4 kHz 10 Hz to 204.8 kHz		31.6 V <sub>peak</sub>	< 20 μV <sub>rms</sub> < 29 μV <sub>rms</sub> < 40 μV <sub>rms</sub> < 60 μV <sub>rms</sub>	< 125 nV <sub>rms</sub> /√Hz	< 15 μV <sub>rms</sub> < 22 μV <sub>rms</sub> < 30 μV <sub>rms</sub> < 44 μV <sub>rms</sub>	< 95 nV <sub>rms</sub> /√Hz
Signal level > 1 V <sub>peak</sub> 10 Hz to 25.6 kHz 10 Hz to 51.2 kHz 10 Hz to 102.4 kHz 10 Hz to 204.8 kHz		31.6 V <sub>peak</sub>	< 200 μV <sub>rms</sub> < 285 μV <sub>rms</sub> < 400 μV <sub>rms</sub> < 600 μV <sub>rms</sub>	< 1250 nV <sub>rms</sub> /√Hz	< 150 μV <sub>rms</sub> < 215 μV <sub>rms</sub> < 300 μV <sub>rms</sub> < 450 μV <sub>rms</sub>	< 950 nV <sub>rms</sub> /√Hz
<b>Spurious-free Dynamic Range re Full-scale Input</b> (Input terminated by 50 Ω or less) Spurious-free Dynamic Range is defined as the ratio of the rms full-scale amplitude to the rms value of the largest spurious spectral component (non-harmonic)		<b>INPUT RANGE</b>	<b>TYPICAL</b>			
		10 V <sub>peak</sub>	160 dB			
		31.6 V <sub>peak</sub>	140 dB			
<b>DC Offset re Full Scale</b> Measured after automatic DC compensation at current temperature when changing from AC to DC coupling or changing input range when DC coupled			<b>GUARANTEED</b>		<b>TYPICAL</b>	
			< – 60 dB		– 80 dB	
<b>Harmonic Distortion Products</b>			<b>GUARANTEED</b>		<b>TYPICAL</b>	
10 V range, 1st harmonic < 5 V <sub>p</sub>			– 80 dB or < 1 μV, whichever is greater		– 100 dB @ 1 kHz	
10 V range, 1st harmonic > 5 V <sub>p</sub>			– 70 dB		– 80 dB @ 1 kHz	
31.6 V range			– 60 dB		– 80 dB @ 1 kHz	
<b>Crosstalk</b>			<b>FREQUENCY RANGE</b>		<b>GUARANTEED</b>	<b>TYPICAL</b>
From Output channel to Direct/Mic. Preamp./ Charge Input channel			0 – 204.8 kHz		– 100 dB	– 140 dB
From Direct/Mic. Preamp. to Charge if BNC/ LEMO connectors are connected during charge measurement. (Not recommended, leave the connectors open.)			0 – 10 kHz 10 – 204.8 kHz		– 100 dB – 60 dB	– 120 dB – 70 dB
From Charge to Direct/Mic. Preamp. if charge signal is connected during direct/ preamp measurement. (Not recommended, leave the charge input open.)			0 – 10 kHz 10 – 204.8 kHz		– 70 dB – 60 dB	– 80 dB – 70 dB
<b>Channel-to-channel Match</b> (10 V <sub>peak</sub> input range)			<b>GUARANTEED</b>		<b>TYPICAL</b>	
Maximum Gain Difference $f_L$ is defined as the –0.1 dB frequency of the high-pass filter			0.1 dB from lower frequency limit, $f_L$ , to 102.4 kHz (0.4 dB at – 10% filter frequency)		±0.01 dB	
Maximum Phase Difference $f_L$ is defined as the –0.1 dB frequency of the high-pass filter						

180114/1

**DIRECT/MICROPHONE PREAMPLIFIER INPUT – TYPE 3161**

Channel-to-channel Match (31.6 V <sub>peak</sub> input range)	Maximum Gain Difference	0.7 dB from lower frequency limit, f <sub>L</sub> , to 204.8 kHz (1 dB at –10% filter frequency)		
	Maximum Phase Difference (within one frame)	8° from lower frequency limit, f <sub>L</sub> , to 204.8 kHz		
Common Mode Rejection in 10 V <sub>peak</sub> input range Values for 31.6 V <sub>peak</sub> range are 10 dB lower		<b>GUARANTEED</b>	<b>TYPICAL</b>	
	0 – 120 Hz	70 dB	80 dB	
	120 Hz – 1 kHz	60 dB	65 dB	
	1 – 10 kHz	40 dB	45 dB	
	10 – 100 kHz	20 dB	40 dB	
Absolute Max. Common Mode Voltage		±15 V <sub>peak</sub> without damage		
		±10 V <sub>peak</sub> without clipping		
		If common mode voltage exceeds the max. value, care must be taken to limit the signal ground current in order to prevent damage. Max. is 100 mA. The instrument will limit the voltage to the stated max. 'without damage' common mode value		
Anti-aliasing Filter At least 90 dB attenuation of those frequencies which can cause aliasing	Filter Type	3rd order Butterworth		
	–0.1 dB @	204.8 kHz		
	–3 dB @	512 kHz		
	Slope	–18 dB/octave		
Supply for Microphone Preamplifiers		±33 V or ±15 V, max. 100 mA		
Supply for Microphone Polarization		200 V ±1 V, or 0 V (set per channel)		
Supply for CCLD		7 to 12 mA from 24 V source, option to DC-couple CCLD power supply		
Tacho Supply		CCLD for Type 2981 (Power supply for legacy types MM-0012 and MM-0024 not available)		
Analogue Special Functions		<b>Microphone Charge Injection Calibration (CIC):</b> All modules with 7-pin LEMO support CIC via dedicated application software and Automation interface <b>Transducers:</b> Supports IEEE 1451.4-capable transducers with standardized TEDS (up to 100 m (328 ft) cable length)		
Overload Detection		<b>Signal Overload:</b> Adjustable detection level is ±1 V <sub>peak</sub> to ±10 V <sub>peak</sub> . Default level is ±10 V <sub>peak</sub> (±7 V <sub>peak</sub> in CCLD mode, ±31.6 V in 31.6 V range) which can be set in Transducer Database (PULSE LabShop, BK Connect). Charge: ±10 V = ±10 nC <b>CCLD Overload:</b> Detection of cable break or short-circuit + detection of CCLD transducer working point fault. Detection level: +2 V/20 V <b>Microphone Preamplifier Overload:</b> Detection of microphone preamplifier current consumption too high or too low. Detection level default is 10 mA/1 mA. Adjustable detection level of 1 to 20 mA or 100 mA if disabled <b>Common Mode Voltage Overload:</b> Detection level is ±10 V		
Protection		If signal input level exceeds the measuring range significantly, the input will go into protection mode until the signal goes below the detection level again for at least 0.5 s. While in protection mode, the input is partly switched off and the input impedance is greatly increased. (The measured value will be strongly attenuated but still detectable). In DC mode, the detection limit is ±12 V in the –10 V <sub>peak</sub> range. In all other measuring modes (except CCLD), the limit is ±50 V <sub>peak</sub> including DC component or ±12 V <sub>peak</sub> AC. In CCLD mode, the limit is +50/–2 V <sub>peak</sub> including DC component or ±12 V <sub>peak</sub> AC. In the 31.6 V range, the limit is ±50 V <sub>peak</sub> .		

**CHARGE INPUT – TYPE 3161**

Frequency Range	0.1 Hz to 204.8 kHz Lower frequency range can be set in PULSE LabShop, BK Connect				
Sampling Rate	524 ksamples/s				
A/D Conversion	2 × 24 bit				
Data Transfer	24 bit				
Input Range	10 nC <sub>peak</sub>				
Input Signal Ground Coupling	Floating or single-ended (grounded to chassis)				
Absolute Maximum Input	±300 nC <sub>peak</sub> without damage				
High-pass Filters		–0.1 DB *	–10% @ **	–3 DB @ **	SLOPE
* Defined as the lower frequency, f <sub>L</sub> , for guaranteed fulfilment of 0.1 dB accuracy in 10 V <sub>peak</sub> range	0.1 Hz –20% high-pass filter	0.44 Hz	0.14 Hz (–20% @ 0.1 Hz)	0.074 Hz	–40 dB/dec.
** Defined as the nominal –10%/3 dB filter frequency	1 Hz –10% high-pass filter	3.1 Hz	1.0 Hz	0.47 Hz	–20 dB/dec.
	7 Hz –0.1 dB high-pass filter	7 Hz	1.45 Hz	0.707 Hz	–20 dB/dec.
	22.4 Hz –0.1 dB high-pass filter	22.4 Hz	15.8 Hz	12.5 Hz	–60 dB/dec.
Absolute Amplitude Precision, 1 kHz, 1 V <sub>input</sub>	±0.05 dB, typ. ±0.01 dB				

**CHARGE INPUT – TYPE 3161**

<b>Amplitude Linearity</b> (linearity in one range)	0 to 60 dB below full scale	±0.05 dB, typ. ±0.01 dB	
	60 to 80 dB below full scale	±0.05 dB, typ. ±0.01 dB	
	80 to 100 dB below full scale	±0.2 dB, typ. ±0.02 dB	
	100 to 120 dB below full scale	typ. ±0.02 dB	
	120 to 140 dB below full scale	typ. ±0.02 dB	
	140 to 160 dB below full scale	typ. ±1 dB	
<b>Overall Frequency Response</b> re 1 kHz, from lower limit $f_L$ to 204.8 kHz		10 $f_L$ to 25.6 kHz: ±0.1 dB, -10% at $f_L$ and 204.8 kHz	
<b>Noise</b> Measured lin. 10 Hz to 204.8 kHz  (input terminated by 1 nF)	<b>Signal Level</b>	<b>GUARANTEED</b>	<b>TYPICAL</b>
	<316 pC <sub>peak</sub>	<20 fC <sub>rms</sub> (<44 aC <sub>rms</sub> /√Hz @1 kHz, a = 10 <sup>-18</sup> )	<14 fC <sub>rms</sub> (<32 aC <sub>rms</sub> /√Hz @1 kHz, a = 10 <sup>-18</sup> )
	>316 pC <sub>peak</sub>	<250 fC <sub>rms</sub> (<550 aC <sub>rms</sub> /√Hz @1 kHz, a = 10 <sup>-18</sup> )	<200 fC <sub>rms</sub> (<440 aC <sub>rms</sub> /√Hz @1 kHz, a = 10 <sup>-18</sup> )
<b>Spurious-free Dynamic Range re Full-scale Input</b> (Input terminated by 1 nF)		<b>TYPICAL</b> 150 dB	
<b>DC Offset re Full Scale</b>		Not applicable	
<b>Harmonic Distortion Products</b> (first harmonic < 5 nC <sub>p</sub> )	<b>1st Harmonic</b>	<b>GUARANTEED</b>	<b>TYPICAL</b>
	0.1 Hz – 25.6 kHz	-80 dB	-100 dB @ 1 kHz/1 nC
	0.1 Hz – 51.2 kHz	-70 dB	
	0.1 Hz – 102.4 kHz	-65 dB	
<b>Crosstalk</b> Between input and output channels of a module or between any two channels in different modules. Not applicable if using Front Panel UA-2117 as a multiplexer		<b>FREQUENCY RANGE</b>	<b>GUARANTEED</b>   <b>TYPICAL</b>
		0 – 25.6 kHz	-96 dB   -120 dB
		25.6 – 204.8 kHz	-86 dB   -120 dB
<b>Channel-to-channel Match</b> (same input range)	<b>Maximum Gain Difference</b>	<b>GUARANTEED</b>	<b>TYPICAL</b>
		0.1 dB from 3 × lower frequency limit, $f_L$ , to 1/3 upper limit, $f_U$ 0.8 dB at $f_L$ , 0.4 dB at $f_U$	±0.01 dB
	<b>Maximum Phase Difference</b>	<p style="text-align: right;">180110/1</p>	
<b>Channel-to-channel Match</b> (any input range)	<b>Maximum Gain Difference</b>	<b>GUARANTEED</b>	<b>TYPICAL</b>
		0.2 dB from 3 × lower frequency limit, $f_L$ , to 1/3 upper limit, $f_U$ 1 dB at $f_L$ , 0.5 dB at $f_U$	±0.02 dB
	<b>Maximum Phase Difference</b>	<p style="text-align: right;">180110/1</p>	
<b>Common Mode Rejection</b>		<b>Guaranteed</b>	
	50 – 120 Hz	40 dB (equal to 10 pC/V)	
	120 Hz – 1 kHz	40 dB (equal to 10 pC/V)	
	1 – 25 kHz	30 dB (equal to 32 pC/V)	
<b>Absolute Max. Common Mode Voltage</b>		±15 V <sub>peak</sub> without damage	
		±10 V <sub>peak</sub> without clipping	
		If common mode voltage exceeds the max. value, care must be taken to limit the signal ground current in order to prevent damage. Max. is 100 mA. The instrument will limit the voltage to the stated max. 'without damage' common mode value	

## CHARGE INPUT – TYPE 3161

Anti-aliasing Filter At least 90 dB attenuation of those frequencies which can cause aliasing	Filter Type	3rd order Butterworth
	-0.1 dB @	204.8 kHz
	-3 dB @	512 kHz
	Slope	-18 dB/octave
Analogue Special Functions		Analogue Self-test: Functional check
Overload Detection		Signal overload Common mode voltage overload

## OUTPUT – TYPE 3161

Output Connector	BNC	
Output Coupling	DC	
Signal Ground Coupling	Floating or grounded to chassis	
D/A Conversion	24 bit	
DC Offset (DC Value set to 0 V)	≤1 mV auto-adjusted by loopback (<- 80 dB re full scale)	
Output Voltage Range (DC)	0 to ±10 V ±0.5% of requested value	
Output Voltage Range (AC)	10 $\mu$ V <sub>peak</sub> – 10 V <sub>peak</sub>	
Output Impedance	50 $\Omega$	
Output Load	Max. 40 mA <sub>peak</sub>	
Frequency Range	0 – 204.8 kHz	
Frequency Response re 1 kHz	±0.1 dB, 1 mHz to 102.4 kHz ±0.3 dB, 102.4 kHz to 204.8 kHz	
Frequency Accuracy	0.00025%	
Frequency Resolution	1 mHz (defined in PULSE LabShop, BK Connect)	
Phase Resolution	100 mdegrees (defined in PULSE LabShop, BK Connect)	
Phase Deviation Between Channels	<20 mdegrees for frequencies below 1 kHz*	
Waveform	Software determined arbitrary waveforms up to 2 Msamples Waveforms available in PULSE LabShop, BK Connect: Single fixed sine (continuous or burst), single swept sine, dual fixed sine, fixed sine plus swept sine, stepped sine (with SSR analyzer), random (continuous or burst), pseudo-random, periodic random User-defined, arbitrary waveforms can be downloaded	
Amplitude Linearity @ 1 kHz	±0.1 dB	<b>GUARANTEED</b>
		0 – 100 dB below 7 V <sub>rms</sub>
Harmonic Distortion Products	1st harmonic < 51.2 kHz	<- 80 dB or <1 $\mu$ V, whichever is greater
	1st harmonic 51.2 – 204.8 kHz	<- 76 dB or <3 $\mu$ V, whichever is greater
Spurious In Band (non-harmonic)	0 – 204.8 kHz	1 $\mu$ V
Spurious Out of Band (non-harmonic)	Up to 1 MHz	<- 80 dB re full range output
Absolute Amplitude Precision	@ 23 °C, 1 kHz, 1 V <sub>rms</sub>	<b>GUARANTEED</b>
		±0.05 dB
Crosstalk From input channel to output channels of a module	<b>Range</b>	<b>GUARANTEED</b>
	0 – 204.8 kHz	-100 dB
Common Mode Rejection	1 Hz – 1 kHz	<b>GUARANTEED</b>
		50 dB
Maximum Common Mode Voltage	±15 V <sub>peak</sub> , DC – 80 MHz If common mode voltage exceeds the max. value, care must be taken to limit the signal ground current in order to prevent damage. Max. is 100 mA. The instrument will limit the voltage to the stated max. 'without damage' common mode value	
Reconstruction Filter	Third order Butterworth (-3 dB frequency = 485 kHz typically, -0.1 dB @ 255 kHz)	
	Attenuation of Mirror Frequencies	>80 dB
	Overload Detection	Reported to PULSE LabShop and BK Connect; indicated by light rings on output connectors for output voltage above 11 V <sub>peak</sub> and output current above 40 mA <sub>peak</sub>
	Monitor Output	V <sub>out</sub> = V <sub>in</sub> – signal taken after analogue high-pass filters and input differential amplifier removing common mode signals and CCLD working voltage (≈12 V DC) in CCLD mode

\* Signal generators are not synchronized between LAN-XI and IDA<sup>e</sup> generator modules. This does not affect continuous signals (random) but is not suitable for burst random signals and sine signals requiring phase control between generators.

**INPUT CHANNELS – TYPE 3053**

Frequency Range	DC to 25.6 kHz or any range defined by high-pass filters and by software decimation set in 'frequency span'				
Sampling Rate	65.5 ksamples/s				
Data Transfer	24 bit				
Input Voltage Range	1 V <sub>peak</sub> 10 V <sub>peak</sub>				
Input Signal Coupling	Differential	Signal ground is 'floating' (1 MΩ re chassis)			
	Single-ended	Signal ground is connected to chassis ('Grounded')			
Input Impedance	Direct: 1 MΩ    <300 pF				
	CCLD: >100 kΩ    <300 pF				
Absolute Maximum Input	±60 V <sub>peak</sub> without damage				
High-pass Filters		- 0.1 DB*	-10% @ **	-3 DB @ **	SLOPE
* Defined as the lower frequency, f <sub>L</sub> , for guaranteed fulfilment of -0.1 dB accuracy ** Defined as the nominal -10%/-3 dB filter frequency *** Single analogue pole + 2nd order digital filter section	0.1 Hz -10% digital high-pass filter	0.5 Hz	0.1 Hz	0.05 Hz	- 20 dB/dec.
	0.7 Hz -0.1 dB digital high-pass filter	0.7 Hz	0.15 Hz	0.073 Hz	
	1 Hz analogue -10% high-pass filter	5 Hz	1.0 Hz	0.5 Hz	- 20 dB/dec.
	7 Hz -0.1 dB digital high-pass filter	7 Hz	1.45 Hz	0.707 Hz	
	22.4 Hz -0.1 dB analogue*** high-pass filter	22.4 Hz	14.64 Hz	11.5 Hz	- 60 dB/dec.
	Intensity filter (analogue)	112 Hz	23.00 Hz	11.2 Hz	- 20 dB/dec.
Absolute Amplitude Precision, 1 kHz, 1 V input	±0.05 dB, typical ±0.01 dB				
Amplitude Linearity (linearity in one range)	0 to 60 dB below full scale	±0.1 dB, typ. ±0.01 dB			
	60 to 80 dB below full scale	±0.2 dB, typ. ±0.02 dB			
	80 to 100 dB below full scale	typ. ±0.05 dB			
Overall Frequency Response re 1 kHz, from lower limit f <sub>L</sub> to upper limit f <sub>U</sub> f <sub>L</sub> is defined as the lower frequency for guaranteed fulfilment of -0.1 dB accuracy (see under High-pass Filters) f <sub>U</sub> is defined as the chosen frequency span	±0.1 dB				
Noise Measured lin. 10 Hz to 25.6 kHz (input terminated by 50 Ω or less)	Input Range	GUARANTEED		TYPICAL	
	1 V <sub>peak</sub>	<7.5 μV <sub>rms</sub> (<47 nV <sub>rms</sub> /√Hz @ 1 kHz)		<5.5 μV <sub>rms</sub> (<35 nV <sub>rms</sub> /√Hz @ 1 kHz)	
	10 V <sub>peak</sub>	<75 μV <sub>rms</sub> (<470 nV <sub>rms</sub> /√Hz @ 1 kHz)		<55 μV <sub>rms</sub> (<350 nV <sub>rms</sub> /√Hz @ 1 kHz)	
Spurious-free Dynamic Range re full scale input (input terminated by 50 Ω or less)	Input Range	TYPICAL			
	1 V <sub>peak</sub>	130 dB			
Spurious-free Dynamic Range is defined as: The ratio of the rms full scale amplitude to the rms value of the peak non-harmonic spectral component		130 dB			
	10 V <sub>peak</sub>	120 dB with DC coupling			
DC Offset re Full Scale Measured after automatic DC compensation at current temperature when changing from AC to DC coupling or changing input range when DC coupled	GUARANTEED		TYPICAL		
	< - 80 dB		< - 90 dB		
Harmonic Distortion (all harmonics)	GUARANTEED		TYPICAL		
	- 80 dB in 1 V range - 75 dB in 10 V range		- 100 dB @ 1 kHz		
Crosstalk Between any two channels of a module or between any two channels in different modules	FREQUENCY RANGE	GUARANTEED		TYPICAL	
	0 - 25.6 kHz	- 80 dB		- 100 dB	
Channel-to-channel Match (10 V <sub>peak</sub> and 1 V <sub>peak</sub> input ranges)	GUARANTEED		TYPICAL		
	Maximum Gain Difference f <sub>L</sub> is defined as the -0.1 dB filter frequency	0.1 dB, from lower frequency limit, f <sub>L</sub> , to 25.6 kHz (0.4 dB at -10% filter frequency)		±0.01 dB	
Maximum Phase Difference f <sub>L</sub> is defined as the -0.1 dB filter frequency					
Sound Intensity Phase Match	Not relevant				

## INPUT CHANNELS – TYPE 3053

Common Mode Rejection		GUARANTEED		TYPICAL	
		10 V range	1 V range	10 V range	1 V range
	0.1 Hz – 120 Hz	60 dB	80 dB	65 dB	85 dB
	120 Hz – 1 kHz	50 dB	70 dB	55 dB	75 dB
	1 kHz – 25.6 kHz	30 dB	50 dB	40 dB	60 dB
Absolute Max. Common Mode Voltage		±5 V <sub>peak</sub> without damage			
		±3 V <sub>peak</sub> without clipping			
		If common mode voltage exceeds the max. value, care must be taken to limit the signal ground current in order to prevent damage. Maximum is 100 mA. The instrument will limit the voltage to the stated max. 'without damage' common mode value			
Anti-aliasing Filter At least 90 dB attenuation of those frequencies which can cause aliasing	Filter Type	3rd order Butterworth			
	-0.1 dB @	25.6 kHz			
	-3 dB @	64 kHz			
	Slope	-18 dB/octave			
Supply for Microphone Preamplifiers		Not available			
Supply for Microphone Polarization		Not available			
Supply for CCLD		3.6 mA from 24 V source			
		If any CCLD-coupled channel is paralleled with another channel, this must also be CCLD-coupled. Otherwise the signal might be clipped by the paralleled channel			
Tacho Supply		CCLD for Type 2981 (Power supply for legacy types MM-0012 and MM-0024 not available)			
Analogue Special Functions		Transducers: Supports IEEE 1451.4 capable transducers with standardized TEDS			
Overload Detection		<p><b>Signal overload:</b> Detection level is ±1 V<sub>peak</sub> in 1 V range and ±10 V<sub>peak</sub> in 10 V range (±7 V<sub>peak</sub> in CCLD mode)</p> <p><b>CCLD overload:</b> Detection of cable break or short-circuit + detection of CCLD transducer working point fault. Detection level: +2 V/20 V</p> <p><b>Common mode voltage overload:</b> Detection level: ±3 V</p> <p><b>Protection:</b> If signal input level exceeds the measuring range significantly, the input will go into protection mode until the signal goes beyond the detection level again – but at least for 0.5 s. While in protection mode, the input is partly switched off and the input impedance is strongly increased. (The measured value will be strongly attenuated but still detectable.)</p> <p><b>Detection level:</b> Direct mode: ±33 V<sub>peak</sub>, CCLD mode: +27/ -2 V<sub>peak</sub></p>			

## Channel Specifications – Module Type 3056

### HIGH-SPEED TACHOMETER CHANNELS

Available on channels 1 to 4:

	PULSE LABSHOP	BK CONNECT TIME DATA RECORDER
Ch. 1	<ul style="list-style-type: none"> <li>High-speed tacho signal</li> <li>Normal input</li> </ul>	<ul style="list-style-type: none"> <li>High-speed tacho signal</li> <li>Normal input</li> </ul>
Ch. 2	<ul style="list-style-type: none"> <li>High-speed tacho ref</li> <li>Normal input</li> </ul>	<ul style="list-style-type: none"> <li>High-speed tacho ref</li> <li>Normal input</li> </ul>
Ch. 3	<ul style="list-style-type: none"> <li>High-speed tacho signal</li> <li>Normal input</li> </ul>	<ul style="list-style-type: none"> <li>Normal input</li> </ul>
Ch. 4	<ul style="list-style-type: none"> <li>High-speed tacho ref</li> <li>Normal input</li> </ul>	<ul style="list-style-type: none"> <li>Normal input</li> </ul>

**Analogue Bandwidth:** >1 MHz @ 5 V<sub>peak</sub> (TTL level)

**Tacho Resolution:** 15 ns

**Max. Tacho Input Voltage:** 10 V<sub>peak</sub>

**Absolute Max. Input Voltage:** ±60 V<sub>peak</sub>

**Trigger Level:** 0.2 V to 7 V

**Default Trigger Level:** 1.5 V

Triggering on rising or falling edge

UPPER RPM LIMIT	MAX. PULSES/REVOLUTION	ANGULAR RESOLUTION (°)
1000	60000	0.0000025
6000	10000	0.000015
20000	3000	0.00005
150000	400	0.00375

### AUXILIARY INPUT CHANNELS (simultaneously sampled)

**Number of Channels:** 8 DC channels in 2 × 10-pin LEMO connectors

**Input Connector:** 2 × 10-pin LEMO

**Sampling Rate:** 16 Hz

**Input Connection:** Single-ended

**Input Voltage Range:** ±10 V in one range

**Input Protection:** 50 V

**Input Impedance:** 1 MΩ || 300 pF

**Precision:** ±0.1% of reading ±1 mV offset (after warm up time)

**Noise:** <3 μV (10 mHz – 8 Hz) measured without temperature drift and DC offset

**Noise-free Dynamic Range:** 120 dB (typical)

**Noise-free Resolution:** 19 to 20 bits (typical)

**Temperature Coefficient:** <15 μV/°C (typical)

**Distortion:** 90 dB @1 Hz 10 V<sub>peak</sub> (typical)

**Programmable DC Output Channels:** 4 open-drain outputs (2 per connector) able to sink 100 mA from an external supply of typically 24 V, which allow simple relay control (on/off, pass/fail, etc.) via Automation interface

**DC Output without External Supply:** 5 V, max. 50 mA

**DC Output Protection:** 40 V

**DC Out Supply:** 5 V out, max. 100 mA total for module

**INPUT CHANNELS (DYN-X) – TYPE 3056**

Frequency Range	DC to 51.2 kHz Lower frequency range can be set in PULSE LabShop, BK Connect					
Sampling Rate	131 ksamples/s					
A/D Conversion	2 × 24 bit					
Data Transfer	24 bit					
Input Voltage Range	10 V <sub>peak</sub> Extended range: 31.6 V <sub>peak</sub>					
Input Signal Coupling	Differential	Signal ground is 'floating' (1 MΩ re chassis)				
	Single-ended	Signal ground is connected to chassis ('Grounded')				
Input Impedance	Direct, Microphone: 1 MΩ    <300 pF					
	CCLD: >100 kΩ    <300 pF					
Absolute Maximum Input	±60 V <sub>peak</sub> without damage					
High-pass Filters		- 0.1 dB *	-10% @ **	-3 dB @ **	Slope	
* Defined as the lower frequency, f <sub>L</sub> for guaranteed fulfilment of -0.1 dB accuracy in 10 V <sub>peak</sub> range	0.1 Hz -10% analogue high-pass filter	0.5 Hz	0.1 Hz	0.05 Hz	-20 dB/dec.	
	0.7 Hz -0.1 dB digital high-pass filter	0.7 Hz	0.15 Hz	0.073 Hz		
** Defined as the nominal -10%/3 dB filter frequency	1 Hz -10% digital high-pass filter	5 Hz	1.0 Hz	0.5 Hz	-20 dB/dec.	
	7 Hz -0.1 dB digital high-pass filter	7 Hz	1.45 Hz	0.707 Hz		
	22.4 Hz -0.1 dB analogue high-pass filter	22.4 Hz	15.8 Hz	12.5 Hz	-60 dB/dec.	
	Intensity filter (analogue)	115 Hz	23.00 Hz	11.5 Hz	-20 dB/dec.	
Absolute Amplitude Precision, 1 kHz, 1 V <sub>input</sub>	±0.05 dB, typ. ±0.01 dB					
Amplitude Linearity (linearity in one range)	0 to 80 dB below full scale	±0.05 dB, typ. ±0.01 dB				
	80 to 100 dB below full scale	±0.2 dB, typ. ±0.02 dB				
	100 to 120 dB below full scale	typ. ±0.02 dB				
	120 to 140 dB below full scale	typ. ±0.02 dB				
	140 to 160 dB below full scale	typ. ±1 dB				
Overall Frequency Response re 1 kHz, from lower limit f <sub>L</sub> to upper limit f <sub>U</sub> f <sub>L</sub> is defined as the lower frequency for guaranteed fulfilment of -0.1 dB accuracy in 10 V <sub>peak</sub> range (see under High-pass Filters.) DC: f <sub>L</sub> = 0 f <sub>U</sub> is defined as the chosen frequency span	±0.1 dB ±0.3 dB in 31.6 V range					
Noise	INPUT RANGE	GUARANTEED		TYPICAL		
* Measured lin. 10 Hz to 25.6 kHz or lin. 10 Hz to 51.2 kHz: (Input terminated by 50 Ω or less)	Signal level <316 mV <sub>peak</sub> 10 Hz to 25.6 kHz 10 Hz to 51.2 kHz	10 V <sub>peak</sub>	LIN* <4 μV <sub>rms</sub> <13 μV <sub>rms</sub>	1 KHZ <25 nV <sub>rms</sub> /√Hz	LIN* <3 μV <sub>rms</sub> <10 μV <sub>rms</sub>	1 KHZ <19 nV <sub>rms</sub> /√Hz
	Signal level >316 mV <sub>peak</sub> 10 Hz to 25.6 kHz 10 Hz to 51.2 kHz	10 V <sub>peak</sub>	<60 μV <sub>rms</sub> <350 μV <sub>rms</sub>	<375 nV <sub>rms</sub> /√Hz	<50 μV <sub>rms</sub> <250 μV <sub>rms</sub>	<313 nV <sub>rms</sub> /√Hz
	Signal level <1 V <sub>peak</sub> 10 Hz to 25.6 kHz 10 Hz to 51.2 kHz	31.6 V <sub>peak</sub>	<20 μV <sub>rms</sub> <45 μV <sub>rms</sub>	<125 nV <sub>rms</sub> /√Hz	<15 μV <sub>rms</sub> <35 μV <sub>rms</sub>	<95 nV <sub>rms</sub> /√Hz
	Signal level >1 V <sub>peak</sub> 10 Hz to 25.6 kHz 10 Hz to 51.2 kHz	31.6 V <sub>peak</sub>	<200 μV <sub>rms</sub> <1200 μV <sub>rms</sub>	<1250 nV <sub>rms</sub> /√Hz	<150 μV <sub>rms</sub> <800 μV <sub>rms</sub>	<950 nV <sub>rms</sub> /√Hz
Spurious-free Dynamic Range re Full-scale Input (Input terminated by 50 Ω or less) Spurious-free Dynamic Range is defined as the ratio of the rms full-scale amplitude to the rms value of the largest spurious spectral component (non-harmonic)	INPUT RANGE	TYPICAL				
	10 V <sub>peak</sub>	160 dB				
	31.6 V <sub>peak</sub>	140 dB				
DC Offset re Full Scale Measured after automatic DC compensation at current temperature when changing from AC to DC coupling or changing input range when DC coupled	GUARANTEED		TYPICAL			
	< -90 dB		-100 dB			
Harmonic Distortion (all harmonics)	GUARANTEED		TYPICAL			
	-80 dB (-60 dB in 31.6 V range)		-100 dB @ 1 kHz (-80 dB @ 1 kHz in 31.6 V range)			
Crosstalk Between any two channels of a module or between any two channels in different modules	FREQUENCY RANGE		GUARANTEED	TYPICAL		
	0 to 51.2 kHz		-100 dB	-140 dB		

**INPUT CHANNELS (DYN-X) – TYPE 3056**

<b>Channel-to-channel Match</b> (10 V <sub>peak</sub> input range)		<b>GUARANTEED</b>	<b>TYPICAL</b>
	Maximum Gain Difference f <sub>L</sub> is defined as the –0.1 dB frequency of the high-pass filter	0.2 dB from lower frequency limit, f <sub>L</sub> , to 51.2 kHz (0.4 dB at –10% filter frequency)	±0.05 dB
	Maximum Phase Difference (within one frame) f <sub>L</sub> is defined as the –0.1 dB frequency of the high-pass filter		
<b>Channel-to-channel Match</b> (31.6 V <sub>peak</sub> input range)		<b>GUARANTEED</b>	<b>TYPICAL</b>
	Maximum Gain Difference	0.6 dB from lower frequency limit, f <sub>L</sub> , to 51.2 kHz (1 dB at –10% filter frequency)	
	Maximum Phase Difference (within one frame)	4 degrees from lower frequency limit, f <sub>L</sub> , to 51.2 kHz	
<b>Sound Intensity Phase Match</b> (only for using intensity filter and in 10 V <sub>peak</sub> input range) All channels matched		<b>GUARANTEED PHASE MATCH</b>	<b>TYPICAL PHASE MATCH</b>
	Frequency Range		
	50 to 250 Hz	±0.017°	±0.005°
	250 Hz to 2.5 kHz	0.017° × (f/250)	±0.005°
	2.5 to 6.4 kHz	±0.17°	±0.08°
<b>Common Mode Rejection in 10 V<sub>peak</sub> input range</b> Values for 31.6 V <sub>peak</sub> range are 10 dB lower		<b>GUARANTEED</b>	<b>TYPICAL</b>
	0 to 120 Hz	70 dB	80 dB
	120 Hz to 1 kHz	55 dB	60 dB
	1 to 51.2 kHz	30 dB	40 dB
<b>Absolute Max. Common Mode Voltage</b>		±5 V <sub>peak</sub> without damage	
		±4 V <sub>peak</sub> without clipping	
		If common mode voltage exceeds the max. value, care must be taken to limit the signal ground current in order to prevent damage. Max. is 100 mA. The instrument will limit the voltage to the stated max. 'without damage' common mode value	
<b>Anti-aliasing Filter</b> At least 90 dB attenuation of those frequencies which can cause aliasing		<b>Filter Type</b>	3rd order Butterworth
		–0.1 dB @	51.2 kHz
		–3 dB @	128 kHz
		<b>Slope</b>	–18 dB/octave
<b>Supply for Microphone Preamplifiers</b>		±14.0 V, max. 100 mA per channel (max. 100 mA total/module)	
<b>Supply for Microphone Polarization</b>		200 V ±1 V, or 0 V (set per channel)	
<b>Supply for CCLD</b>		4 to 5 mA from 24 V source, option to DC-couple CCLD power supply	
<b>Tacho Supply</b>		CCLD for Type 2981 (Power supply for legacy Types MM-0012 and MM-0024 not available)	
<b>Analogue Special Functions</b>		<b>Microphone Charge Injection Calibration (CIC):</b> All modules with 7-pin LEMO support CIC via dedicated application software and Automation interface <b>Transducers:</b> Supports IEEE 1451.4-capable transducers with standardized TEDS (up to 100 m (328 ft) cable length)	
<b>Overload Detection</b>		<b>Signal Overload:</b> Adjustable detection level from ±1 V <sub>peak</sub> to ±10 V <sub>peak</sub> , which can be set in Transducer Database (PULSE LabShop, BK Connect). Default level: ±10 V <sub>peak</sub> (CCLD mode: ±7 V <sub>peak</sub> ; 31.6 V range: ±31.6 V) <b>CCLD Overload:</b> Detection of cable break or short-circuit + detection of CCLD transducer working point fault. Detection level: +2 V/20 V <b>Microphone Preamplifier Overload:</b> Detection of microphone preamplifier current consumption too high or too low. Detection level default: 10 mA/1 mA. Adjustable detection level from 1 to 20 mA or 100 mA if disabled <b>Common Mode Voltage Overload:</b> Detection level: ±3.0 V	
<b>Protection</b>		If signal input level exceeds the measuring range significantly, the input will go into protection mode until the signal goes below the detection level again for at least 0.5 s. While in protection mode, the input is partly switched off and the input impedance is greatly increased. (The measured value will be strongly attenuated but still detectable.) In DC mode, the detection limit is ±12 V in –10 V <sub>peak</sub> range. In all other measuring modes (except CCLD), the limit is ±50 V <sub>peak</sub> including DC component or ±12 V <sub>peak</sub> AC. In CCLD mode, the limit is +50/–2 V <sub>peak</sub> including DC component or ±12 V <sub>peak</sub> AC. In the 31.6 V range, the limit is ±50 V <sub>peak</sub> .	

### NUMBER OF CHANNELS

2 – 12 (hardware module dependent)

### RECORDER CONTROL – SETUP

Accessed through the LAN-XI module's web-based interface:

- Recording name
- Frequency bandwidth of recording
- Duration of recording
- Enable/Disable channels for recording
- Configure channels (for example, sensor power supply, high-pass filter, sensor sensitivity, etc.)

Connection by standard wired LAN or optional through wireless LAN or GSM modem (requires wireless access point or GSM modem)

### RECORDER CONTROL – RECORDING

**Stand-alone:** Record Start/Stop by pushbutton. Module LCD gives recorder status and amount of storage remaining

**Internet Browser:** Record Start/Stop. Level indication of each channel, recorder status, amount of storage remaining, current overload status and latched overload status during recording session

### SUPPORTED INTERNET BROWSERS

Microsoft® Internet Explorer®, Firefox™ (Windows® and Linux®), Safari®, and Chrome™ (also via smartphone)

### DATA STORAGE

**Format:** microSD; SDHC memory card (up to 16 GB, guaranteed with UL-1018)\*

**File Format:** BKC or WAV format with additional measurement/channel information stored in Brüel & Kjær footer

**Transfer Methods:** SD card reader (with included adaptor) or remote via Ethernet connection (> 2 MB/s)

---

\* SDXC memory cards are not supported

## Specifications – Battery Module Type 2831-A

**Type:** Li-ion rechargeable

**Typical Operating Time:** >7 hours with single module, >40 minutes in Type 3660-D-100 frame (up to 2 batteries in Type 3660-D-100)

**Output Voltage:** 14.4 V (nominal)

**Capacity:** 97 Wh

**Status Indicators:** 5 LEDs showing remaining capacity on battery, software access to charging status and remaining capacity in LAN-XI frame

### Charging Time:

- 3 hours in Type 3660-C-100 or -D-100 frame powered from mains
- 3 hours when the frame is powered from external DC†
- 2 hours with ZG-0880 mains charger
- 3 hours with ZG-0858 DC/In-vehicle charger

---

† Valid for frames with serial numbers >110000, hardware version >2.0

## Specifications – LAN Interface

### CONNECTOR

**Modules:** RJ 45 (10baseT/100baseTX) connector complying with IEEE 802.3 100baseX. Individual modules communicate at 100 Mbit/s  
**Frames:** Types 3660-C-100 and -D-100 permit the use of a ruggedized RJ-45 data connector (Neutrik NE8MC-1) to screw the cable to the frame  
Types 3660-C-100 and -D-100 communicate at 1000 Mbit/s. Shielded cables of type 'CAT 5e' or better should be used.

All LAN connectors support MDIX, which means that cables may be 'crossed' or not.

For stand-alone modules, PoE is also supported (IEEE 802.3af). PoE requires screened shielded twisted pair (S/STP or S/FTP) CAT6 LAN cables.

### PROTOCOL

The following standard protocols are used:

- TCP
- UDP
- DHCP (incl. Auto-IP)
- DNS (on top of UDP)
- PTPv2, IEEE 1588 – 2008 (on top of UDP)
- IP
- HTTP (on top of TCP; for web server, etc.)
- Ethernet (IEEE 802.3 with IEEE 802.3X)

### ACQUISITION PERFORMANCE

Each LAN-XI module generates data at almost 20 Mbit/s when acquiring data at maximum bandwidth. The modules are capable of handling their own maximum traffic while the built-in switch in the frame's backplate has more than sufficient capacity. This is very scalable and means that bottlenecks can only occur outside these, for example in:

- External switches
- PC

For convenience, it is possible to daisy-chain two LAN-XI frames. It is not recommended to daisy-chain more than two frames. Generally, a star configuration with a central switch is recommended. This must have a switch capacity well beyond  $N \times 20$  Mbit/s, where  $N$  is the total number of modules. Be aware that this includes data cascaded from other switches 'upstream'

### PTP PERFORMANCE

**PTP Synchronization** (with 1 Gigabit LAN Switch): Typical sample synchronization better than 200 ns (approx.  $\pm 0.07^\circ$  @ 1 kHz,  $\pm 2^\circ$  @ 25.6 kHz)

Tested with:

- Cisco® SG300-10MP, 10-port 10/100/1000 Managed Gigabit Switch with Maximum PoE (8 ports)
- Hirschmann PTP switches

Better performance can be expected with a dedicated switch with PTP:

- UL-0295: 8+2-port network switch with PoE/PoE+ and PTPv2 support, preconfigured for optimal use with LAN-XI and Fusion-LN

LAN-XI Modules

TYPE	DESCRIPTION	INCLUDED FRONT PANEL (DETACHABLE)	ACCESSORIES	
3050-A-060-R	6-ch. Input Module 51.2 kHz (Mic., CCLD, V)	UA-2100-060 Connectors: 6 × BNC	<b>Included Accessories</b> <ul style="list-style-type: none"> <li>ZG-0426: Mains Adaptor (100 – 240 V)</li> <li>AO-1450: Shielded CAT 6 LAN Cable with RJ-45 (2 m)</li> </ul> <b>Optional Accessories</b> Other front panels are available, see <a href="#">BP 2421</a> for a complete overview	
3050-A-040-R	4-ch. Input Module 51.2 kHz (Mic., CCLD, V)	UA-2100-040 Connectors: 4 × BNC		
3052-A-030-R	3-ch. Input Module 102.4 kHz (Mic., CCLD, V)	UA-2100-030 Connectors: 3 × BNC		
3053-B-120-R	12-ch. Input Module 25.6 kHz (CCLD, V)	UA-2107-120 Connectors: 12 × SMB		
3056-A-040	4-ch. Input/HS-Tacho + 8-ch. Aux. Module, 51.2 kHz (Mic., CCLD, V)	UA-2111-040 Connectors: 4 × BNC + 2 × 10-pin		
3057-B-030-R	3-ch. Bridge Input Module 102.4 kHz (Bridge, CCLD, V)	UA-2121-030 Connectors: 3 × D-sub		
3058-B-080	8-ch. Input + 2-ch. CAN Bus Module 25.6 kHz (CCLD, V, Balanced)	UA-3101-080 Connectors: 8 × SMB + 2 × 8-pin		
3160-A-042-R	4-ch. Input + 2-ch. Output Module 51.2 kHz (Mic., CCLD, V)	UA-3100-042 Connectors: 4 × BNC + 2 × BNC		
3160-A-022-R	2-ch. Input + 2-ch. Output Module 51.2 kHz (Mic., CCLD, V)	UA-2100-022 Connectors: 4 × BNC + 2 × BNC		
3161-A-011-R	1 ch. Input + 1 ch. Output Module 204.8 kHz (Mic., CCLD, V)	UA-2117-011 Connectors: 1 × BNC, 1 × 7-pin, 1 × TNC + 2 × BNC		
3050-A-060-X	6-ch. Input Module 51.2 kHz (Mic., CCLD, V)	No included front panel		<b>Included Accessories</b> No accessories included
3050-A-040-X	4-ch. Input Module 51.2 kHz (Mic., CCLD, V)	No included front panel		
3052-A-030-X	3-ch. Input Module 102.4 kHz (Mic., CCLD, V)	No included front panel		
3053-B-120-X	12-ch. Input Module 25.6 kHz (CCLD, V)	No included front panel		
3056-A-040-X	4-ch. Input/HS-Tacho + 8-ch. Aux. Module, 51.2 kHz (Mic., CCLD, V)	No included front panel		
3057-B-030-X	3-ch. Bridge Input Module 102.4 kHz (Bridge, CCLD, V)	No included front panel		
3160-A-042-X	4-ch. Input + 2-ch. Output Module 51.2 kHz (Mic., CCLD, V)	No included front panel		
3160-A-022-X	2-ch. Input + 2-ch. Output Module 51.2 kHz (Mic., CCLD, V)	No included front panel		
3161-A-011-X	1 ch. Input + 1 ch. Output Module 204.8 kHz (Mic., CCLD, V)	No included front panel		
2831-A	Battery Module	UA-2106 Connectors: Not applicable	<b>Included Accessories</b> <ul style="list-style-type: none"> <li>ZH-0686: Single Module to Battery Power Adaptor</li> <li>ZG-0880: Mains Charger (100 – 240 V)</li> </ul> <b>Optional Accessories</b> <ul style="list-style-type: none"> <li>ZG-0858: DC Power Charger with Car Utility Connector</li> </ul>	

LAN-XI Frames

Type	DESCRIPTION	INCLUDED ACCESSORIES	OPTIONAL ACCESSORIES
3660-C-100	LAN-XI 5-module Frame with GPS	<ul style="list-style-type: none"> <li>Built-in mains power transformer with AN-00xx, where xx = country specific cable</li> <li>Ruggedized RJ-45 data connector (Neutrik NE8MC-1)</li> <li>Terminator for IDA<sup>e</sup> Sync (50 Ω)</li> <li>ZZ-0260: GPS antenna (non-magnetic), SMA right-angle, 5 m (16.4 ft)</li> </ul>	<ul style="list-style-type: none"> <li>AO-1490: Type 3660-D-100 Frame DC Power Cable</li> <li>AO-1489: Type 3660-D-100 Frame DC Power to Car Utility Connector</li> <li>AO-0087-D-xxx: BNC Cable for synchronization of combined LAN-XI and IDA<sup>e</sup> systems, xxx = length in decimetres</li> </ul>
3660-D-100	LAN-XI 11-module Frame with GPS		
3660-A-20X	LAN-XI 1-module Wireless LAN Frame		

## Supported Accessories

### SENSORS

A wide range of accelerometers, microphones, preamplifiers and sound intensity probes is available for use with LAN-XI systems. Systems support IEEE 1451.4-capable transducers with standardized TEDS. Please see [www.hbkworld.com](http://www.hbkworld.com).

### CABLING

AO-0090	Cable, floating ground, BNC (M) to circular-1B 7-pin (M)
AO-0091	Cable, floating ground, BNC (F) to circular-1B 7-pin (M)
AO-0526	Cable, coaxial, 1/4"-28 UNF 4-pin (F) to 3 × BNC (M)
AO-0546	Cable, DC power, circular-00 (M) to plug for car power outlet, 3 m (10 ft)
AO-0548	Cable, DC power, 2 × FASTON™ (F) to 4 × circular-00 (M) for powering 4 modules, 2.9 m (9.5 ft)
AO-1450	Cable, shielded CAT 6 LAN, 2 × RJ-45 (M)
AO-0738-D-010	Cable, for Type 3056, 2 × circular 10-pin (M) to 8 × BNC (F), 1.0 m (3.3 ft), max. 70 °C (158 °F)
JJ-0081	Adaptor, BNC (F) to BNC (F)
JJ-0152	T-adaptor, 1 × BNC (M) and 2 × BNC (F)
JP-0145	Adaptor, BNC (M) to 10-32 UNF (F)
JP-0162	Adaptor, TNC (M) to 10-32 UNF (F)

### POWER SUPPLY

ZG-0426-PTO	Mains adaptor, 90 to 264 V AC to 15 V DC/2.4 A 36 W, C7 (M)
-------------	---

### DATA ACQUISITION AND CONDITIONING

WB-1497	20 dB Attenuator
UL-1018	SD memory card, 16 GB microSD with 3-in-1 kit (SD, miniSD or microSD)
ZH-0699	Break-out Box (for Type 3056)

### NETWORKING

UL-0295	Network switch with PoE/PoE+ and PTPv2 support, 8 × RJ-45 and 2 × SFP+ ports, preconfigured for optimal use with LAN-XI and Fusion-LN
---------	---

### PC

PCs are constantly updated. Contact your local office for latest information

Type 7201-G-xx	Dell® High-end Notebook
Type 7202-G-xx	Dell Standard Tower
Type 7203-C-xx	Dell High-end Tower
Type 7204-A-RU	Crete Military Spec Notebook

xx specifies the country (DE, DK, ES, FR, GB, IT, RU, SE, or US);  
y specifies the inclusion of Microsoft® Office Pro (1 = not included, 2 = included)

### PC ACCESSORIES

UL-0200	Vehicle Adaptor (12 – 32 V) for Type 7204-A-RU
UL-0255-xx	Dell 24" Widescreen LCD Flat Panel Monitor

xx specifies region (EU, UK or US)

---

## Calibration Services

ANA-LNXI-CAF	Accredited Calibration
ANA-LNXI-CAI	Initial Accredited Calibration
ANA-LNXI-CTF	Traceable Calibration
ANA-LNXI-TCF	Conformance Test with Certificate